

MODEL 64

Operator Manual



Contents

Preface	2
Caution	2
Address	2
The AMI Model 64 Oxygen Probe Analyzer	3
Introduction	3
Features:	3
Options:	3
Oxygen sensor:	4
Gas compatibility	4
Sensor life	4
Any indication of abuse or tampering will void the warranty.	4
Installation and Operation	5
Receiving the analyzer	5
Precaution	5
Installation.	5
Location:	5
Probe connection:	6
Display unit connections:	7
Initial test:	7
Output connections:	7
Sample connection:	7
Sensor Installation:	7
Notes:	7
Operation	9
Calibration:	9
Maintenance and troubleshooting	10
Maintenance:	10
Periodic Calibration:	10
Specifications and Disclaimer	11
Specifications:	11
Disclaimer	12

Preface

The AMI series of analyzers provide the latest in high-definition oxygen analysis. The series includes trace oxygen, percent oxygen and portable trace and percent oxygen models. Most of them share the same basic design, using time proven oxygen sensors and advanced high definition electronics for noise and interference free performance.

The Model 64 is an extremely compact oxygen probe that contain a zirconium oxide sensor and all associated electronics using an advanced microprocessor design. It produces a linear voltage output corresponding to 0-25% oxygen. It requires no supporting electronics and is so stable that it can usually be installed and forgotten over its entire life. The sensor is expected to last up to ten years in continuous operation, and indefinitely in storage. This means that these units can be stored as spare parts for years and used immediately with no need for replacing the sensor.

As options it can be supplied with either 4-20mA isolated output or an RS-232 digital output. An optional display unit can also be supplied.

Caution

Read and understand this manual fully before attempting to use the instrument. In particular understand the hazards associated with using flammable or poisonous gases, and associated with the contents of the sensor used.

Address

Advanced Micro Instrument

225 Paularino Ave

Costa Mesa, CA 92626

www.amio2.com

(714) 848-5533

Last Revised: 09/20/2022

OM-300-021 Rev C

The AMI Model 64 Oxygen Probe Analyzer

Introduction

The Advanced Micro Instruments Oxygen Probe is designed for monitoring of oxygen content in a nitrogen or similar inert gas stream. It operates on a single range, normally 0-25% oxygen, and produces an output typically 0-2.5V DC over this range. It uses 7 - 24V DC power, and it provides both a power and signal ground for lower signal offset. No calibration is provided internally: calibration is performed either by the host system to which it is attached or else by the optional meter display unit.

Features:

- Percent oxygen in non-flammable samples
- General purpose self-contained oxygen sensor
- Extremely stable, long-life sensor
- Virtually unaffected by temperature changes
- Virtually unaffected by barometric pressure changes
- Virtually unaffected by humidity changes
- Virtually unaffected by flow rate changes
- Calibration interval 6 months
- Very small size
- Standard 0-1V output
- Isolated 4-20mA output optional
- RS232 communications optional
- Very low cost

Options:

- Display unit
- 0-50% range
- 0-95% range
- 4-20mA output
- RS232 bidirectional communications
- Diffusion screen
- Barbed fittings
- Compression fittings

Oxygen sensor:

AMI uses a unique zirconium oxide sensor. This sensor measures the concentration of oxygen in a gas stream, using an oxygen specific chemistry. It generates an output current in proportion to the amount of oxygen present, and has zero output in the absence of oxygen, thus avoiding any requirement to zero the analyzer. The cell is almost linear throughout its range, and a built-in microprocessor corrects the residual non-linearity to better than 0.1%. The span calibration may be performed using standard span gases or ambient air, but the sensor is so stable that calibration is ordinarily not necessary.

Percent level analyzers are routinely calibrated on air. Air has a reliable 20.94% oxygen in it, when dry. In the case of its use as an area monitor it is advisable to use a known high quality air supply for calibration since the room air may not contain 20.94% of oxygen! High range sensors should be calibrated with a gas whose concentration is near the top of the range – 50% for the 0-50% unit, and 95% for the 0-95% unit.

Gas compatibility

The zirconium oxide sensor operates internally at red heat, with platinum as its electrodes. This means that any oxidizable gases will react with any oxygen present and burn, reducing the apparent oxygen reading. It also means that gases which can decompose at high temperatures will do so. In the case of Freons this can produce hazardous byproducts. It also means that flammable mixtures of gases may be ignited. Sulfur containing gases and acid gases such as SO₂ will degrade the sensor and shorten its life.

DO NOT USE THIS PROBE WITH FLAMMABLE GASES OR HALOGEN CONTAINING GASES!!

Sensor life

Unlike electrochemical sensors, the model 65 sensor does not degrade when it is not in use. Its life depends on the total amount of oxygen to which it is exposed, while it is powered up. If it is powered continuously, and exposed to air, the sensor will remain almost completely stable for about several years, and thereafter will gradually drop its reading for the next few years. If it is run on an 8 hour duty cycle, it will last three times as long. If it is run continuously at 5% oxygen, it will last at least 6 years before the sensor **starts** to change. If it is run at 5% oxygen on an 8 hour duty cycle, it will last maybe 18 years before the sensor **starts** to change.

Installation and Operation

Receiving the analyzer

Precaution

When you receive the instrument, check the package for evidence of damage and if any is found, contact the shipper.

Installation.

Location:

The probe may be installed in any orientation. Typically the gas connections are pointing downwards, but this is not necessary.

Mount the display unit (if used) in a suitable panel opening with 8-32 (or equivalent) screws. This unit should be within about 6 feet of the probe.

Connect the cable provided to the probe and to the display unit, or suitable power supply (7-28V DC) and monitoring system.

If the display unit is used, connect it to a suitable power supply (7 –28V DC), and connect the output if desired to a suitable monitoring system.

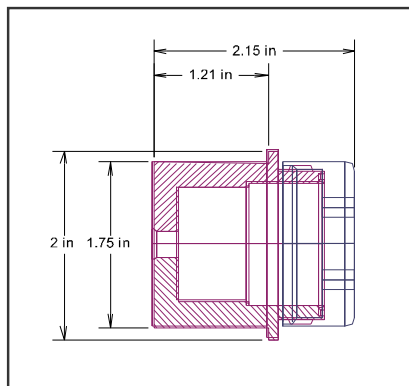

Figure 1. Probe dimensions

Probe connection:

(Probe mounted without display unit)

The unit requires a DC power supply between about 7 and 28 volts, at less than 500 mA. The actual current consumption is greater at low voltages than high voltages, and is typically about 250mA at 12V. The supply should be free of high frequency noise - if it is derived from a switching power supply it is advisable to use a series inductor and parallel capacitors to filter it. The unit provides a regulated 5V DC output at up to 50 mA for external use. If the display unit is used, connect this power output to it.

The probe is provided with a length of cable attached. If this length is not sufficient, an additional length may be added up to a distance of about 100ft. However, make sure the wire gauge is adequate for the current carried – and preferably provide a separate signal ground which you should connect as close as possible to the probe, and run in parallel with the power return. Otherwise the voltage drop due to the return current will give an offset to the output voltage. Make the connection in a suitable connection box. The cable used must be a pair of shielded twisted pairs.

Wire color	Connection
Brown	+7 to +28 VDC, 100 to 500mA
Black	Ground/Return
White	Voltage output
Blue	+5V, 50mA max

Display unit connections:

The Display unit is designed to be connected to the probe, and to provide a calibrated output signal. It needs between 7 and 28V DC power as above, and uses the 5V supply from the probe as the power for its meter. The first four connections are made to the probe; the second four are user connections.

Back Panel Terminal	Probe Connection
Probe 1	Brown
Probe 2	Black
Probe 3	Blue
Probe 4	White
PWR+	+7-28V DC
PWR-	Ground
O/P+	4-20mA +
O/P-	4-20mA -

Initial test:

Install the unit as desired, and connect it to some form of monitoring system. Turn on the power, and wait for about 5 minutes for the sensor to warm up, and to stabilize.

Expose the unit to air, and calibrate the monitoring system to 20.94% oxygen (or equivalent nitrogen for nitrogen purity systems). The unit should be recalibrated after about one day, and thereafter at a rate determined by usage, though once every six months month is typical.

Output connections:

The voltage output circuit is capable of driving an input resistance of 10K Ohms or more. Lower input resistances will degrade the accuracy of the circuit.

Sample connection:

The probe is provided with two barbed fittings. These are mounted into 1/8" NPT female orifices, and so may be removed and appropriate compression fittings used instead. It may be desirable to provide a tee in the line for calibration - see the discussion below. Sample flow rate should be between 0.1 SCFH and 10 SCFH, the exact amount not being critical. Avoid back-pressuring the sensor with excess flow if there is any restriction on the exhaust.

Sensor Installation:

The sensor is permanently mounted in the probe, and does not require separate installation.

Notes:

The unit is designed to be mounted on a suitable clip in a general purpose area. It is not suitable for installation in a hazardous area though it may be mounted outdoors if the temperature range does not exceed the -4°F to 122°F (-20°C - 50°C) for which it is rated. The cable supplied is approximately 6 ft long.

Do not mount it close to sources of electrical interference such as large transformers, motor start contactors, relays etc. Also avoid subjecting it to significant vibration. Make sure that the sensor cable does not run next to high-current cables, or AC cables. Preferably the sensor cable should be in its own conduit.

If used as an area monitor the probe should be mounted where it will sense a representative sample of the room air. If the room has no natural circulation, you may want to install a fan to make sure that there is some air movement. The nature of the possible asphyxiating gas also should affect its placement - if the danger is from a heavy gas such as CO₂, the sensor should be mounted low down so that it detects the gas before people start breathing it, while if the gas is light such as helium, the sensor should be mounted higher. Otherwise it should normally be mounted at head height.

DO NOT USE THIS PROBE WITH HALOGEN CONTAINING GASES SUCH AS FREONS!

Operation

Calibration:

The sensor will stabilize within a few minutes, and the probe may be calibrated almost as soon as it has been installed.

Probe only option:

No provision is made in the probe itself for calibration. It is expected that the display or monitoring device will perform this function. The output of the sensor will be very close to 2.09V on air, and may not need further calibration. The following section is intended to provide tips on performing calibration if necessary.

Display option:

Use the span potentiometer provided on the display unit to calibrate the output. Expose the probe to air (or 90% oxygen for the high range version), and adjust the span pot until the meter reads the correct value (20.9% or 90.0%). The voltage output will then be calibrated to 1V full scale.

Be absolutely sure that you are using at least a certified, and preferably a primary standard span gas supply as the span gas. Alternatively use known fresh air. So called "Manufactured air" or bottled compressed air often has an oxygen content that is significantly different from its label.

If the calibration is to be performed in software, bear in mind the following points.

1. The most common error is that the user attempts to span the system on an incorrect gas, often nitrogen. Some limitation must be made therefore in the permissible gain of the system so that this condition is detected. Typically the gain is allowed to vary no more than 25% between calibrations. However it is still possible for a calibration to be sufficiently in error that the system cannot be recalibrated again once it has been messed up. Therefore it must be possible to force a calibration no matter the apparent error.
2. The calibration routine should detect an excessive drift and delay calibration until the drift has stopped, or abort the process if no good reading can be obtained. This might happen because of an inadequate calibration gas flow, due perhaps to an empty cylinder.
3. The calibration routine should allow at least 60 seconds for the reading to stabilize.
4. If the system performs an automatic calibration, some means of alerting the user to calibration failure must be made.

Maintenance and troubleshooting

Maintenance:

The AMI oxygen probe is maintenance free other than for periodic calibration.

Periodic Calibration:

The probe should be calibrated about once every six months to obtain the best accuracy. The sensor will remain stable for several years depending on the application, and then degrade at the rate of less than 1% a month if it is operated continuously. Use in a particularly aggressive environment may degrade the sensor faster: in this case calibrate more often.

Specifications and Disclaimer

Specifications:

Standard ranges:

Single range: 0 - 25% (0 – 95% optional)

Sensitivity: 0.5% of full scale

Repeatability: +/- 1% of full scale at constant temperature

Operating temperature: : -4°F to 122°F (-20°C - 50°C).

Humidity: < 85%, non-condensing

Operational conditions: Pollution degree 2, Installation category I I.

Drift: < +/- 1% of full scale in 4 weeks at constant temperature

Response times:

90% of full scale < 13 seconds

Outputs: 0 - 2.5 VDC

Power requirements: Between 7 and 28 VDC (nominally 24VDC) Typically 250 mA at 12V with no external draw from the 5V supply. Current draw is higher at lower voltage and lower at higher voltage.

Dimensions: 2.15 Dia x 2" high (not including fittings or leads).

Weight less than 1 lb

Disclaimer

Although every effort has been made to assure that the AMI analyzers meet all their performance specifications, AMI takes no responsibility for any losses incurred by reason of the failure of its analyzers or associated components. AMI's obligation is expressly limited to the analyzer itself.

In particular, the AMI analyzer is designed for operation with non-flammable samples in a general purpose, i.e. non-hazardous area. Any damage resulting from its use in a hazardous area or with flammable or explosive samples is expressly the responsibility of the user.

The AMI analyzer is not designed as a primary safety device, that is to say it is not to be used as the primary means of assuring personnel safety. In particular it is not designed to act as a medical instrument, monitoring breathing air for correct oxygen concentration, and should not be used as such when it is the only safety device on the gas system.

Accuracy

A loose term. In general with analyzers when we use the word "accuracy" we really mean "repeatability", the degree to which an analyzer can repeat the same measurement reading on the same gas. All analyzers really compare the measured gas against a known standard, and the accuracy of their measurement is therefore dependent upon this standard.

Bulkhead

Refers to a method of mounting an analyzer where the back of the analyzer is mounted flush against a panel or wall, while the body of the analyzer extends out in front of it, like a box hung on a wall's surface rather than inset.

Electrochemical

A type of chemical reaction which produces an electrical current as part of the reaction. In this case, the oxygen sensors produce an electrical current in proportion to the amount of oxygen present at their membrane surface.

LCD

Liquid Crystal Display - a form of digital display suitable for reading in bright light conditions. The display degrades below about -20C and above about 60C.

Output - voltage or current

An analog voltage or current proportional to the oxygen measurement as a percentage of range, suitable for driving a chart recorder or computer input. A current output is preferred as it is less subject to interference than a voltage signal.

Panel

A type of mounting where the analyzer is inserted into a vertical panel so that the face plate is visible on the panel, while the body of the analyzer extends behind it.

Process

Refers to the sample that is supposed to be analyzed. Typically an analyzer measures the product of a chemical or physical process, and this is generally referred to as the "Process"

Range

The operational range of measurement of the analyzer. This is set by its amplifier sensitivity. Oxygen levels higher than the range full-scale will not be measured accurately. Normally the analyzer should be measuring oxygen concentrations between 20 and 80 percent of its range.

Response

The response time of an analyzer is defined as the time taken to go from the beginning of a noticeable change to 90% of the final level. The beginning is often defined as 10% of the final level. This is also called the "t90" time. The transit time of the gas is not included in this measurement.

RFI

Radio Frequency Interference. All analog circuits are prone to interference from high level radio frequencies, and special precautions must be taken to prevent this. The quality of such design is referred to by the acronym EMC, or electromagnetic compatibility - the property of being compatible with any practical electromagnetic environment.

Span

To calibrate the upper end of the range of measurement, as opposed to the bottom end or zero. Generally this is done by exposing the sensor to a gas of known concentration, and making the analyzer read that value.

Trace

Low levels of, in this case, oxygen. This term is used to describe unwanted levels of oxygen as a contaminant, typically in the low ppm levels.

AMI[®] WARRANTY & SUPPORT

LIMITED WARRANTY/DISCLAIMER

The warranty period is **TWO YEARS** for the Analyzer. Any failure of material or workmanship will be repaired free of charge for that specified period from the original purchase (shipping date) of the instrument. AMI will also pay for 1-way ground shipment back to the customer.

The warranty period for the electrochemical oxygen sensor is 6 months.

The warranty period for the electrochemical H₂S sensor is 6 months.

The warranty period for the zirconium oxide sensor is 2 years.

Any indication of abuse or tampering of the instrument will void the warranty.

Receiving the Analyzer

When you receive the instrument, check the package for evidence of damage and if any is found contact the shipper. Although every effort has been made to assure that the Analyzer meets all performance specifications, AMI takes no responsibility for any losses incurred by reason of the failure of this analyzer or associated components. AMI's obligation is expressly limited to the Analyzer itself.

EXCEPT FOR THE FOREGOING LIMITED WARRANTY, AMI MAKES NO WARRANTIES, EXPRESS, IMPLIED OR STATUTORY, AS TO THE NON-INFRINGEMENT OF THIRD-PARTY RIGHTS, MERCHANTABILITY, OR FITNESS FOR A PARTICULAR PURPOSE. IF APPLICABLE LAW REQUIRES ANY WARRANTIES WITH RESPECT TO THE SYSTEM, ALL SUCH WARRANTIES ARE LIMITED IN DURATION TO TWO (2) YEARS FROM THE DATE OF DELIVERY.

LIMITATION OF LIABILITY

IN NO EVENT WILL AMI BE LIABLE TO YOU FOR ANY SPECIAL DAMAGES, INCLUDING ANY LOST PROFITS, LOST SAVINGS, OR OTHER INCIDENTAL OR CONSEQUENTIAL DAMAGES, EVEN IF THE COMPANY HAS BEEN ADVISED OF THE POSSIBILITY OF SUCH DAMAGES, OR FOR ANY CLAIM BY ANY OTHER PARTY.

LIMITATION OF REMEDIES

AMI's entire liability and your exclusive remedy under the Limited Warranty (see above) shall be the replacement of any Analyzer that is returned to the Company and does not meet the Company's Limited Warranty.
