

# Oxygen Analyzer Manual

## Model 210BR



Costa Mesa, CA



# Contents

<b>Preface</b>	<b>1</b>
Thank you!	1
Caution	1
Address	1
<b>Model 210BR Oxygen Analyzer</b>	<b>2</b>
Introduction	2
Features:	2
Oxygen sensor:	4
Sensor Warranty:	4
Instrument Warranty:	4
Receiving the analyzer	4
<b>Important:</b>	<b>5</b>
Points to consider first!	5
Location:	6
Safety Considerations:	7
<b>Installation Procedure</b>	<b>8</b>
<b>Analyzer Description</b>	<b>20</b>
Basic description:	20
Drawings:	21
General Information	23
Basic knowledge about oxygen measurement	23
Analyzer operation	24
Sample tubing and components	24
Exhaust	24
Calibrating the analyzer	24
Using the analyzer	26
Output Range	26

Security:	26
Communications	26
Advanced Features	27
<b>Maintenance and troubleshooting</b>	<b>28</b>
Maintenance:	28
Periodic Calibration:	28
Sensor Replacement:	28
Sensor replacement cautions:	29
Sensor replacement procedure:	29
Troubleshooting	30
Basics of oxygen troubleshooting	30
<b>Accessories</b>	<b>34</b>
<b>Specifications and Disclaimer</b>	<b>37</b>
Specifications:	37
Disclaimer	38

# Preface

## Thank you!

We would like to thank you for purchasing the most advanced trace oxygen analyzer available. We have gone to great lengths to make this analyzer as simple, and complete, as possible. It includes our patented cell block, (patent numbers 5,728,289 and 6,675,629), and our patented sensor. It uses the most sophisticated electronics with complete microprocessor control to provide many advanced features while retaining the extreme ease of use for which this line of analyzers is famous. It is CSA approved to UL standards for use in a wide variety of flammable gas applications in general purpose and Class 1 Division 1 Group BCD hazardous areas, such as natural gas, petrochemical refining and head space monitoring. With the optional demister and liquid rejection probe accessory it provides a complete system for monitoring trace oxygen in harsh environments with difficult, hot and wet samples.

Please verify that the analyzer was not damaged in transit. If so please contact the shipper as well as AMI.

## Caution

Read and understand this manual fully before attempting to use the instrument. In particular understand the hazards associated with using flammable or poisonous gases.

## Address

Advanced Micro Instruments

225 Paularino Avenue

Costa Mesa, CA 92626

(714) 848-5533

[www.amio2.com](http://www.amio2.com)

Last Revised 11/07/2019

# Model 210BR Oxygen Analyzer

## Introduction

The Advanced Micro Instruments Oxygen Analyzer Model 210BR provides the latest in high precision oxygen measurement. It is specifically designed for use with flammable gases in hazardous areas, and includes a number of features that make it particularly suitable for this application. It is approved by CSA to UL standards for Class 1 Div. 1 Group BCD using flammable gas samples.

This manual covers software version 5.24.

## Features:

- Compact size
- Unique patented cell block
- 4 Selectable output ranges
- Auto-ranging display with user-selectable output range
- Three levels of security access settable via the USB interface: no front panel settings allowed, span only allowed and complete access allowed.
- Front panel sensor access
- Optional air or span gas calibration, no zero gases required
- Virtually unaffected by hydrocarbons or other oxidizable gases
- Integrated sample system
- Metering valve flow control
- H<sub>2</sub>S resistant sensor up to 10ppm H<sub>2</sub>S
- Optional 500ppm H<sub>2</sub>S resistant sensor available
- High accuracy and fast response
- Large liquid crystal display
- Bi-directional serial output with simple protocol
- Bi-directional Modbus™ support over RS485 multi-drop loop
- Backed by a two year warranty (excluding sensor)
- Choice of analog outputs: a current output of 4-20mA or a voltage output of 1-5V, both isolated
- Two fully adjustable alarm relay contact closures 24VDC/110VAC @ 5A resistive
- Programmable alarm delay
- Front panel alarm and output hold off/bypass with programmable delay
- Programmable pulse drivers for latching-type solenoid valves
- Built-in data logging with real time clock
  - Logs oxygen, temperature, power supply voltages
- Optional low-power heater for stand-alone operation in inclement weather
- Approved for Class 1 Div. 1 Group BCD
- Optional 117 VAC/12-24VDC operation
- Automatic logging of low power, start up and calibration events
- USB connectivity

## **Oxygen sensor:**

AMI manufactures its own electrochemical sensor. It measures the concentration of oxygen in a gas stream, using an oxygen specific chemistry. It generates an output current in proportion to the amount of oxygen present, and has zero output in the absence of oxygen, thus avoiding any requirement to zero the analyzer. The cell is linear throughout its range. The span calibration may be performed using standard span gases or ambient air. Unlike competitive sensors, the AMI sensor is made using a high capacity metallic body that provides long life with about twice the active ingredients usually used.

## **Sensor Warranty:**

The sensor is warranted to operate for a period determined by its class. If the sensor ceases to operate correctly before this time has elapsed, contact AMI for a return authorization for evaluation. If there is any evidence of defective material or workmanship the sensor will be replaced free of charge.

NOTE: Any evidence of abuse or physical damage, such as a torn membrane, will void the warranty.

## **Instrument Warranty:**

Any failure of material or workmanship will be repaired free of charge for a period of two years from the original purchase (shipping date) of the instrument. AMI will also pay for one way shipment (back to the user).

This warranty does not cover the sensor, which is covered by its own warranty (see above).

Any indication of abuse or tampering will void the warranty.

## **Receiving the analyzer**

When you receive the instrument, check the package for evidence of damage and if any is found, contact the shipper.

## Important:

*This section contains important information to do with safety and installation. Please don't skip it!*

### Points to consider first!

**Environment** – what is the temperature range going to be where the analyzer will be installed? If the temperature is going to go below freezing, you either need a heated version, a heated version in an extreme weather enclosure, or to place it in a temperature controlled shelter. Also, make sure it won't get too hot in the summer – you may need to ventilate or even put it in an air conditioned building. Use a solar panel as a sunshield if one is to be used. The standard (non-heated) temperature specification is 25°F to 115°F; with a heater it can go to -20°F; in the optional extreme weather enclosure it can go to -40°F.

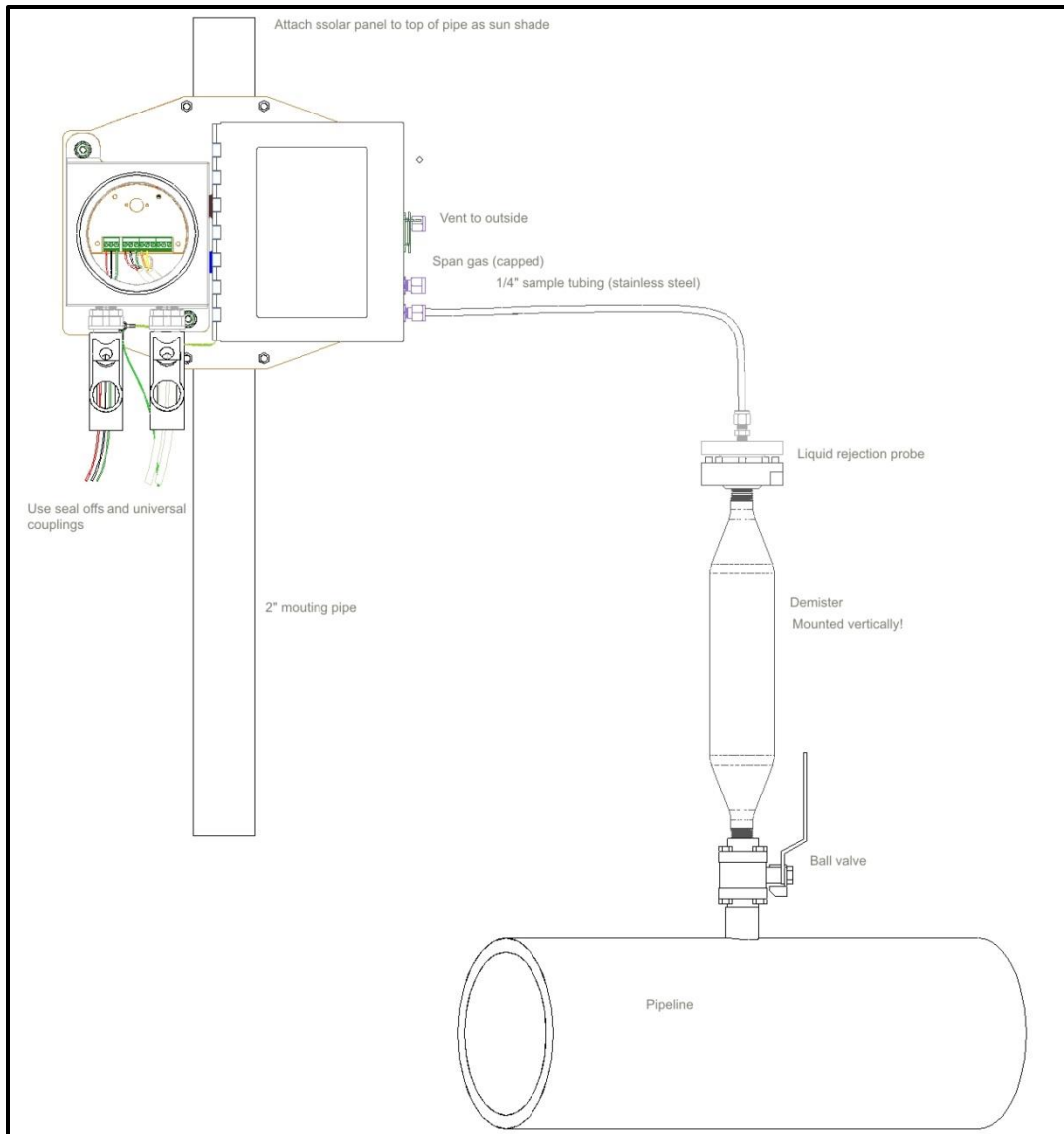
**Sample conditions** – if your sample is hot and wet, you will need to keep water from condensing in the sample line or analyzer. The AMI demister brings hot and wet gases back to ambient temperature and allows the condensation and entrained liquids to fall back into the pipeline (no draining is necessary, unlike a coalescing filter which requires routine maintenance). The Liquid Rejection Probe stops occasional slugs of water from contaminating the analyzer, and acts as a check valve, so that if a compressor goes down drawing a vacuum on the line, air is not drawn back into the analyzer through its vent - it is available with a built-in pressure regulator for high pressure lines (up to 1200psig).

**Power supply** – if you are going to run the unit off solar power, using a battery, you need to size both the battery and the solar panel correctly. The analyzer draws about 30mA at 14.4 volts, but if you select the 4-20mA output option this will go up to about 60mA. A heater draws up to 1.67A when the temperature is at its coldest. We suggest that you use the solar panel as the sunshield for the analyzer by mounting it right over the analyzer.

**Electrical connections** – make sure you use conduit seal-offs on the two conduit entrances located on the bottom of the explosion proof housing, and we suggest you also use universal couplers so you can disconnect the analyzer without cutting wires (if the unit has to be moved or removed for service). Following best electrical practices, run the analog output connections separately from the power and alarm connections. Modbus communications if used should be run with the analog output wiring, using twisted pair wires for both circuits. Run the alarm wires in the same conduit as the power wires.

**Solenoid valves** – if the analyzer is going to be used to control gas flow (such as to shut in contaminated gas) using solenoid valves, consider using latching type valves and the analyzer pulse feature so as to minimize power consumption, particularly if you are using a battery as the power supply. Standard solenoid valves require power to remain open (or closed), whereas latching valves require power only when changing their position. This conserves a lot of power.





**Figure 1. Typical installation showing LRP and demister**

### Location:

Mount the analyzer on a wall or on a 2" pipe in a general purpose, Class 1 Division 1 Group B,C,D area or Class 1 division 2 Group B,C,D area. When equipped with the optional heater, or the extreme weather enclosure, it may be mounted outdoors, though it should be given a sun shield if in direct sunlight (consider using the solar panel if one is used as the sunshield). Mount it at a suitable viewing level.

## Safety Considerations:



---

The unit **MUST** be installed according to the requirements in the National Electrical Code, particularly those of article 500, the section that deals with hazardous atmospheres.

---



---

For AC units, an external circuit breaker or switch **MUST** be provided to allow disconnection of the AC power, in close proximity to the analyzer and within easy reach of the operator!

---

**The ground stud on the main panel MUST be made to a good earth, with a resistance to ground of less than 1 Ohm USING AT LEAST 16AWG WIRE.**

117VAC version is to be installed only in installation (overvoltage) category I or II.

**ELECTRICAL SEAL-OFFS ARE REQUIRED ON ALL THE CONDULET ENTRIES, whether the area classification is Division 1 or Division 2.** We suggest that you use universal couplings between the analyzer and the seals so that you can disconnect the analyzer if necessary without cutting wires.

The unit is designed for installation in either a general purpose or a Class 1 Div. 1 or Div. 2 Group B,C,D area, but it is also designed so that a hazardous gas may be introduced into its main enclosure (the box on the right hand side) as it is intrinsically safe. This gas may be any group B,C or D gas.

The unit consists of two enclosures mounted on a back panel. The smaller enclosure on the left is explosion-proof and contains the electrical connections for the user, and also the power supply and safety components for the other enclosure.

The larger enclosure on the right contains the controls, the analytical circuitry, the sample handling components and the oxygen sensor. This circuitry is designed for intrinsic safety and approved as meeting requirements for Class 1 Div. 1 Group B,C,D by CSA to UL standards.

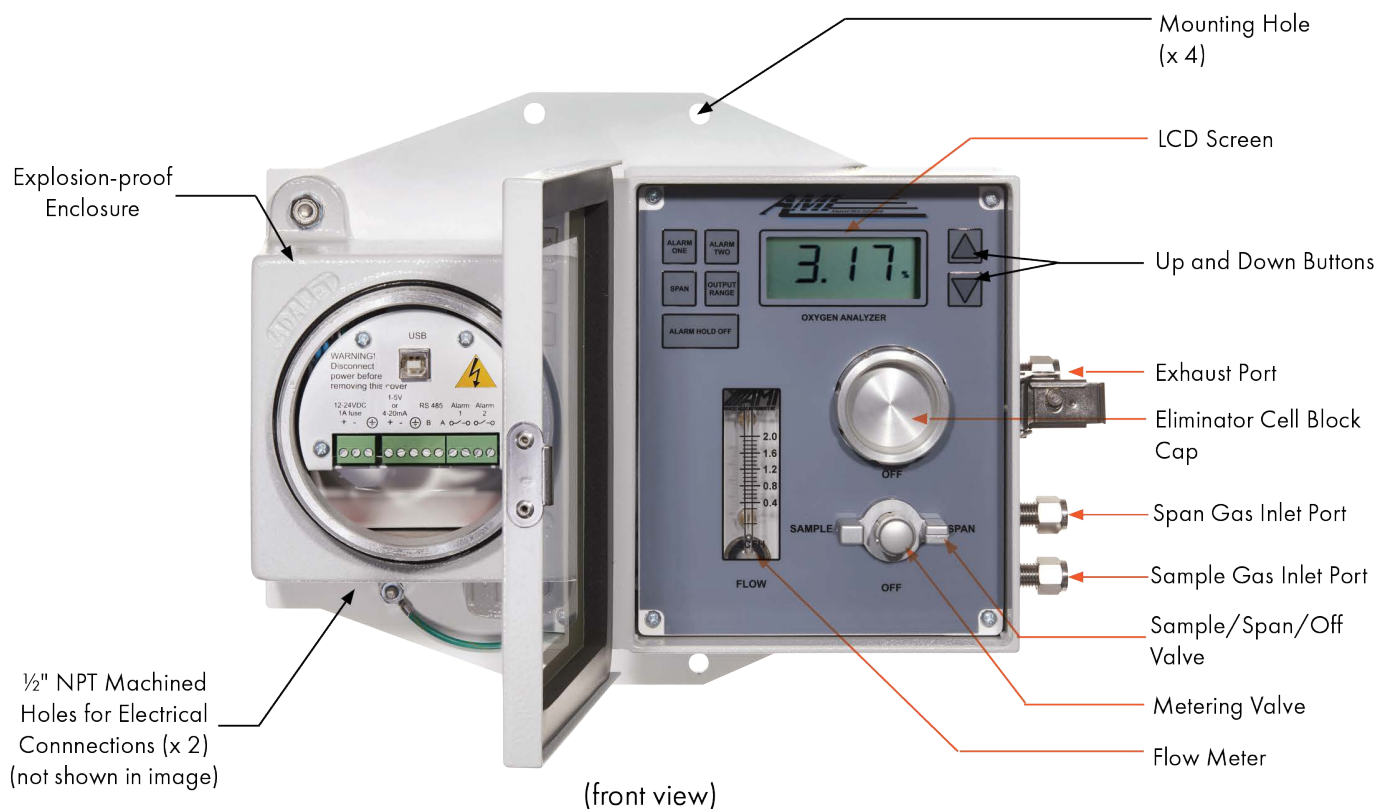
There is a USB connection available from the explosion-proof section. This may be wired up permanently, or may be used occasionally by removing the explosion-proof cap. If so, the area **MUST** be declassified first.

The sample vent should be brought to a safe place – don't let it vent a flammable sample inside a meter/analyzer building.



**Violation of the National Electrical Code installation requirements may cause a fire or explosion, with potential for serious injury or loss of life.**

## Installation Procedure



**Figure 2. The 210BR**

**1. Mount analyzer in a shelter if possible, at a convenient eye level, not too close to the right wall.**

The basic analyzer is designed for operation between 25°F and 115°F. It is available with a heater, which expands its temperature range to -20°F, and an additional extreme weather enclosure which expands it to -40°F. The gas connections are made on the right side of the analyzer, while the electrical connections are at the bottom of the explosion proof enclosure on the left side. Explosion proof seals must be used, so be sure

to leave enough room under the analyzer for these, and for the conduit run. Leave enough space on the right side of the analyzer for the gas connections.

The analyzer can be mounted on a wall, or on a two inch pipe.

If the analyzer is mounted outside, make sure it has some kind of sun shade. If it is DC powered with a solar panel, use the panel to give the analyzer shade.

If the analyzer is mounted in a building with other equipment, make sure it won't get too hot during the summer. The sensor will become noisy and eventually fail in temperatures higher than 115°F. You may need to install ventilation or even air conditioning.

**2. Connect the analyzer ground to an 8 ft. ground rod (or similar high quality ground) using at least 16AWG wire.**

It is **essential** for safety that the analyzer has a good ground. Normally an 8ft rod pounded into the ground will suffice, but in very dry or sandy areas something better may have to be done. Sometimes gas running in pipelines can develop serious static charges on the lines, causing the pipeline to be at a high voltage compared with the local ground. Be aware of this and make sure the pipeline is well grounded itself.

**3. Confirm sample pressure is less than the analyzer specification (150psig). If it is higher, use a suitable regulator such as the high pressure AMI Liquid Rejection Probe. Such a regulator must have a stainless steel diaphragm.**

The analyzer needs a minimum of about 1 PSIG, and a maximum of 150psig sample pressure. If the pressure is too low, the gas flow will be low and the response time long, and if the flow is very low the effect of minor leaks will become significant. If the pressure is too high the analyzer will be damaged, and you may get a hazardous situation if the sample is flammable.

The response time will depend on the length of tubing, the diameter and the flow rate of gas through it. You can roughly calculate it by assuming that the volume of tubing – the length multiplied by its internal area – has to be completely replaced by the gas flowing before you get a representative reading. If the sample pressure is high, the volume is effectively increased because more gas is packed into the tubing.

AMI can provide a version of the Liquid Rejection Probe with a built-in regulator that can handle pressures up to 1500psig.

**4. Deal with any potential condensation or liquid contamination issues.**

If the sample may contain condensable liquids, they must be prevented from entering the analyzer. Natural gas, for example, often contains water in vapor or liquid form, and other liquids such as oils, glycols or methanol. Such liquids tend to collect in dips in the sample line, and come through the line as slugs, particularly if the line is cleaned by “pigging” it (sending a cleaning device through it, preceded by a tidal wave of sludge). Compressors heat the gas and also cause liquids to condense, particularly when the gas cools off, so that even apparently dry gas going into a compressor may contain liquids when it comes out. AMI can provide a “Demister” and Liquid Rejection Probe” that together work to prevent problems from hot wet gases. The demister acts to coalesce droplets and cool the gas, while the Liquid Rejection Probe stops

any liquids from getting to the analyzer. Any liquids fall back into the pipeline, thus minimizing maintenance issues. Also, the Liquid Rejection Probe acts to prevent the problems that arise when the source of the gas is shut off while the downstream compressor continues to run, thus pulling a vacuum on the line. Normally this would cause air to be drawn into the line through the analyzer vent, but the Liquid Rejection Probe contains a very sensitive check valve that prevents this.

**5. Connect the sample line with ¼” stainless steel tubing.**

Use stainless tubing only to connect the sample to the analyzer. Other materials are normally not robust enough. Normally ¼” tubing is adequate unless the sample run is very long and the source pressure low – in this case you may have to use wider tubing.

You should have some kind of blocking valve on the sample port. If you use a Demister, use at least a half inch ball valve at its base.

**6. Turn the Sample/Span/Off valve to the Off position.**

The Sample/Span/Off valve is to the lower right of the grey faceplate above. This valve contains a metering valve in its center. If you turn the Sample/Span/Off valve to the off position, it will stop either sample or span gas from flowing into the analyzer – but the exhaust is still connected to the atmosphere so when you have a sensor in the analyzer it is not sealed off by this valve. At this point in this procedure you shouldn't have the sensor in place yet. Don't use the metering valve to shut off the flow (as it is a fine adjustment valve)!

**7. Pressurize the sample line to line pressure (1 – 150psig).**

The exact pressure doesn't matter – we want enough so that you can easily see leaks in the following step.

**8. Leak check every fitting and weld from the analyzer inlet to the sample tap.**

Use a liquid soap solution such as “Snoop™” or similar. Don't spray it on! You are looking for little bubbles that appear after a while, indicating a leak. Even the tiniest leak will allow oxygen to enter the gas stream, no matter what the pressure inside the line is. Check absolutely every possible source including welds, valve packing, fittings both around the tube and the nut, and anything else that might leak.

**9. Connect the vent line to outside, running slightly downhill all the way.**

Particularly if the analyzer and gas is warmer than the environment, any water vapor in the gas will tend to condense in the vent line. If the line runs uphill, or has a low point, water will collect and potentially freeze, stopping the flow. If the sample gas is flammable, the vent must go to a safe area.

Also take precautions that insects don't make nests in the exhaust line. You may need some sort of a grill over it.

**10. Adjust the sample flow to approximately 1 SCFH with the Flow control valve located in the middle of the Sample/Span/Off valve.**

The Flow Control Valve is the metering valve in the middle of the Sample/Span/Off valve. It is a sensitive needle valve – so don't try to use it to shut off the flow. Turn the main valve to the OFF position for this.

The exact flow rate is not important – 1 SCFH is half way up the flow meter, so is easy to see. You want the flow between about 0.5 SCFH and 2 SCFH at the maximum. Lower flows will result in longer response times. Higher flow rates will tend to increase the pressure on the sensor which will increase the oxygen reading.

**11. Install electrical seal-offs, preferably with electrical couplers. Don't fill them yet.**

**This is critically important!** The electrical safety of the analyzer is based on its being installed properly. If you don't seal off the explosion-proof enclosure you have just made an igniter for the first time you get a gas leak. Explosion-proof seal-offs are devices that allow you to put potting compound around the wires going into and out of the enclosure so that burning gases can't get past them. This compound also means that you can't remove the wires in the future, and if you don't use the universal couplers we recommend (and can supply) it will be very hard for you to remove the analyzer in the future. The couplers allow you to remove the analyzer without having to completely rewire it when you replace it.



**Figure 3. Electrical connections**

**12. Connect power, relay contacts, analog output and RS485 if desired. Run the power and alarms in one conduit, and the analog output and RS485 in the other. Note that you MUST use rigid conduit**

**for Class 1 Div 1 areas. You can use flexible conduit for Class 1 Div. 2 areas. See the NEC handbook.**

All the electrical connections are located in the left hand box – unscrew the cap with the red label. The picture above shows the AC version (recognized by its black color). The DC version looks the same (except it is white). The power is brought to the three position unpluggable terminal strip on the left (DC power looks the same, but it's marked differently). Make sure the wires are connected per the markings – Hot to H, Neutral to N, Ground to the ground symbol. For DC units, connect the positive to the “+” symbol, the negative to the “-” symbol, and the ground as before. For DC units, the “-” and the ground are connected together, but run a separate ground wire to your main ground, and another wire from the – terminal to the negative terminal on your power supply or battery.

The analog output – which may be either 1-5V or 4-20mA – is connected to the “+” and “-” symbols. This signal is isolated from ground. If the device to which you are connecting is also isolated from ground, make sure you ground the “-” connection at the analyzer. The terminal marked by the ground symbol may be used for this purpose, in which case the output is no longer isolated. **DO NOT GROUND BOTH ENDS!** If you do so, you will generate a ground loop which will seriously upset the readings. Normally you would use the ground terminal for a shield. You can select which output is in use. The voltage output is lower power, but more prone to interference. If you decide to change it, you will probably have to perform an output calibration, described later in this manual.

The two terminals marked A and B are for the RS-485 ModBus connection. This is not isolated from ground.

There are two alarm contacts. These are two independent switches that either close, or open, their two terminals. Think of them as being like a single pole light switch. You can determine whether they close upon an alarm, or open, using the user interface program. They can switch up to 110V at 5A. Good practice suggests adding snubbing diodes across any load they switch – although diodes are installed already on the output circuit board. Be careful you don't use them to short the power supply by attaching one end to your hot and the other to ground. This can blow traces off the circuit board.

Each relay can be programmed to switch on or off, above or below set point, and with individual time delays. They can also be set to operate latching valves, so that one contact opens the valve, and the other closes it. Finally, they can themselves be set to reset automatically, or else to latch in position unless someone presses the “Alarm hold off” button on the front panel. The User Interface Program must be used to access all these options.

Run the power and alarm wires through one conduit, and the analog output and RS485 lines through the other.

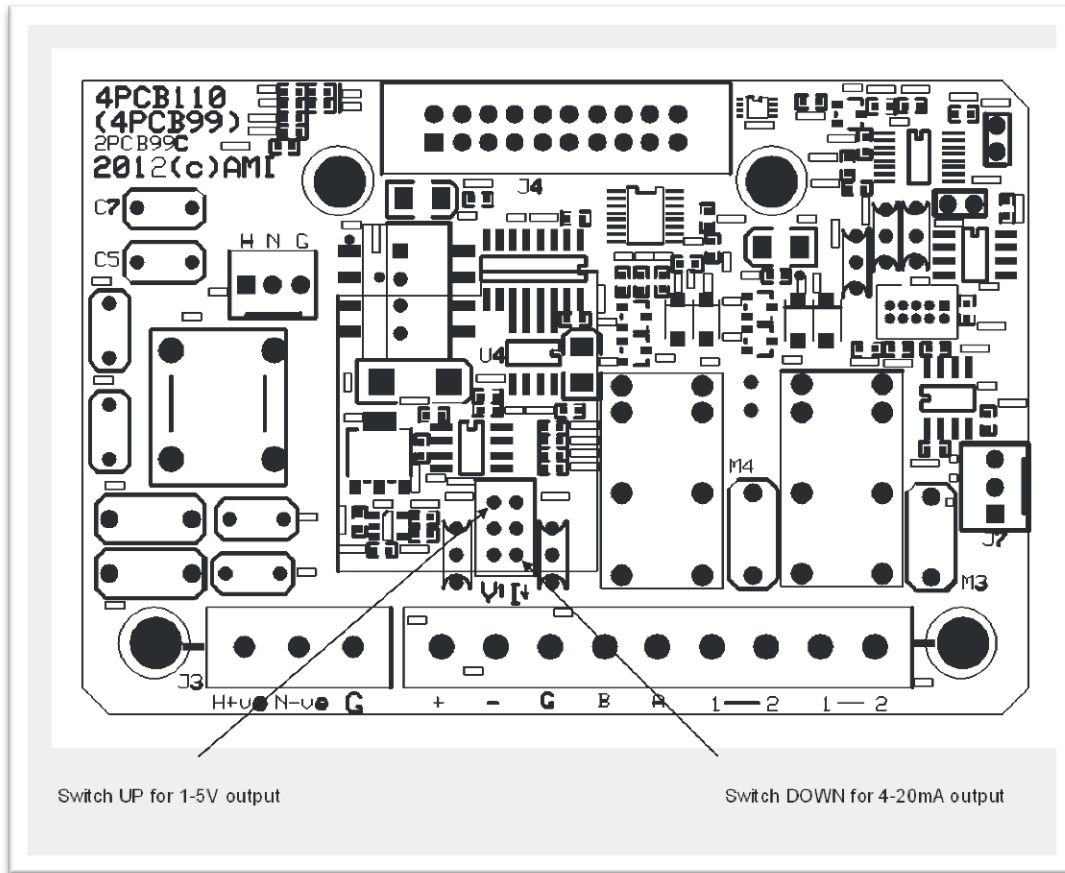
Make sure you are following the NEC (National Electrical Code) when you wire it up. In particular, if the analyzer is in a class 1 Div. 1 area you have to use rigid conduit. You **MUST** always seal it off, in any case. Also make sure you have a way of removing power from the analyzer nearby, per the code.

**And don't drill any holes in the enclosure! This will violate the safety approval, and may cause a fire or explosion resulting in serious injury or loss of life.**





13. Verify the analog output is correct and connect it.



**Figure 4. Output selection switch positions**

This unit is equipped with a selectable analog output. It may be either 1-5V or 4-20mA, selectable via a switch on the output PCB (the board directly under the cover plate in the explosion proof housing). The positioning of the switch is indicated on the PCB itself – put switch one position for 4-20mA, and put it the other for 1-5V. The 4-20mA option will increase the current draw by up to 50mA, if the unit is powered from DC. Note that if you change the position you will have to recalibrate the output using the AMI software.

The output 4-20mA circuit is capable of driving a 600 Ohm load, while the voltage output needs at least a 10,000 Ohm load. Either will saturate at more than 125% of the nominal full scale range.

Using AMI software you can set the output to 4mA, 12mA and 20mA (or 1V, 3V and 5V), and adjust the internal settings to calibrate these values so as to get the most accurate possible transfer of information to a recording or computing device. If you leave a box checked so the output is at some value, like zero, the unit will automatically return to its normal operation after ten minutes.

#### **14. Power up analyzer.**

When you do so, the LCD should light up in the right side enclosure, and you may see some LEDs flicker inside the explosion-proof enclosure. This is normal diagnostic information.

#### **15. If you are not using the advanced features, set up the alarms and the output range from the front panel of the analyzer.**

The controls all work in the same way – first press the button you want to do something to, so that the LCD shows whatever it might be that you have pressed. Then if you want to change it, press the up or down arrows until the number shown reaches what you want. Then let go the button, and after a couple of seconds the LCD will go back to reading oxygen and the change will be stored.

First choose the output range. This is the oxygen range that the analog output and alarms respond to. For example, if you use a range of 10% full scale, 5V or 20mA corresponds to 10%, and 1V or 4mA correspond to zero. Use a range that gives you enough resolution to see normal behavior, but allows you to have reasonable alarm set points.

Set the range by pressing the OUTPUT RANGE button, and then scroll the number on the screen with the UP and DOWN arrows until it says what you want.

When you have set the output range, set the alarms. The alarm set point is shown as a ppm (or percentage) value, but it is internally stored as a percentage of the output range you just chose. If you change the range, the alarm set points will change along with it.

Note that this range has nothing to do with the measurement range of the analyzer. The analyzer LCD automatically scales its reading from 0.01% to 25%; it's only the analog output that gets scaled by the range, not the measurement.

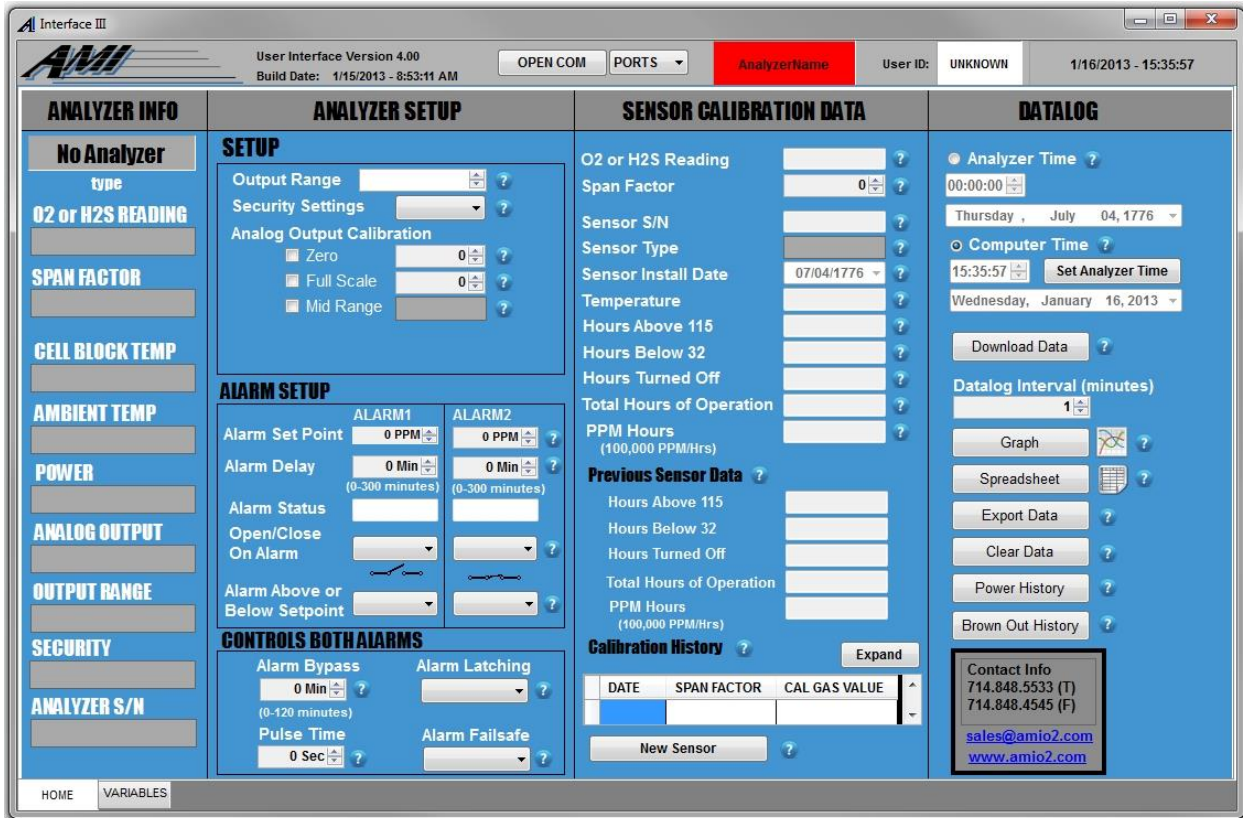
If you want to set up other alarm features, such as whether the alarms latch or open or close on alarm, you have to use the laptop user interface program.

If you press the UP button by itself, i.e. outside of changing something, the LCD will show the "Span factor", a number that indicates how much amplification the oxygen signal needs. As the sensor ages this number is set higher by each successful calibration until it reaches 1000, at which point you should really have already replaced the sensor.

If you press the DOWN button by itself, the LCD will show the temperature of the cell block in degrees Fahrenheit.

#### **16. Optional:**

This section talks about using the laptop to make more advanced choices.



**Figure 5. User interface initial screen**

- a. **Connect the laptop, run the User Interface and verify all alarm, output and security settings.**

Note that you must have power on the analyzer before the laptop can find the communication port! Plug in a standard USB cable (such as the kind often used to connect a PC to a printer) to the port in the middle of the explosion proof enclosure’s shield. Select the comm port at the top of the screen, and click Open COMM. The program will figure out how to communicate to the analyzer, and fill in all the boxes once it connects.

- b. **Set the analyzer clock time, and click on “Clear Data Log”.**

The analyzer stores its readings for about two weeks for you to look at subsequently. It may have some readings stored from the check-out process, and these might confuse you when you subsequently view them. Also, we set it up on PST, and your time zone may be different. So set the time, and clear the data. In due course, click on the Download Data button to see the stored data.

- c. **Verify the output calibration.**

You should only need to do this if you have changed the output selection, or if your flow computer or similar monitoring device has an uncalibrated input.

- i. **Connect the analog output terminals to an appropriate measuring device – preferably the flow computer or similar monitoring device you are going to be using with this analyzer.**

You can simply use a multi meter connected to the output terminals. If so, make sure it is set correctly – don't use a voltmeter to measure current! Often people leave their meter in the current measurement position and the next time they measure a voltage they blow the current fuse. If this has happened, the meter won't measure current until you replace it.

- ii. **Arrange that you can readily see the reading given by this device.**
- iii. **On the AMI User Interface, check the "Zero" check box under SETUP in the ANALYZER SETUP section.**
- iv. **Observe the response of the monitoring device, and adjust the number in the box next to the Zero label until the monitoring device shows what it considers to be zero (which should correspond with either 1V or 4mA).**
- v. **Check the box marked "Full Scale" in the SETUP section, and adjust the number in the box next to it until the monitoring device shows full scale. This corresponds to 5V or 20mA.**
- vi. **Check the "Mid Range" box and verify that the monitoring device shows mid scale.**
- vii. **Uncheck any checked box (if you forget, the analyzer will revert to its ordinary operation in ten minutes anyway).**

**17. Turn the Sample/Span/Off valve to OFF.**

You don't want to be flowing sample gas during the next step.

**18. Unscrew the cell cap, and install the oxygen sensor.**

Unscrew the cap first. Open the sensor bag, remove the sensor by holding the little handle and put it into the cell compartment, gold side up, and with the little metal tag on the side facing you. When it is in place, hold the sensor in place and pull out the tag. Do it in this order so that the sensor is always operating, eating up oxygen that gets in through its membrane.

**19. Optional: in the User Interface press the "NEW SENSOR" button, and record the sensor serial number.**

You might want to write it down. Note that you can read the serial number while the sensor is in place in its cell block pocket – don't leave the sensor out while you write it down.

**20. Stabilize for 45 seconds, adjust span to 20.9%.**

It will take the sensor about 20 seconds to come to a reasonably stable reading, but give it 45 seconds to be sure. Don't go over this time, even if the reading is still moving. The sensor is probably changing temperature a bit which affects its reading until it has equilibrated with the analyzer. You aren't concerned with the utmost precision at this point, just a close-enough value.

**21. IMMEDIATELY turn the Sample/Span/Off valve to SAMPLE.**

Do this before you screw on the cell cap, because you will get rid of most of the air in the cell pocket immediately, helping the sensor come down quickly.

**22. If present, remove the USB cable.**

**23. Replace the Cell cap and tighten it down.**

Make sure you don't cross thread it, and make sure it is tightened down firmly but not so much you will need a tool to undo it. There is no need to panic about getting it on fast, since the flow of sample gas will purge the sensor while you are working on it.

**24. Seal the electrical seals.**

It is essential that you do this! Follow the instructions that come with the seal-offs.

**25. Screw on the cap on the explosion-proof (left side) section of the analyzer.**

Again, this is essential.

**26. If desired, span with known calibration gas.**

- a) **Connect a regulator to the span gas tank.**
- b) **Shut off the regulator outlet valve and leak check all fittings, gauges and packing glands with Snoop™ or equivalent.**

Again, flow the liquid on, don't spray it on. Make sure you check the regulator and tank valve as well.

- c) **Flow calibration gas preferably through a length of AMI supplied tubing WHILE you are connecting the tubing to the span gas fitting. Allow the gas to purge around the fitting for about 20 seconds before you tighten it.**

It is preferable to use the AMI special flexible non-diffusive tubing with its O-ring sealed fittings so that you don't destroy the span inlet fitting on the analyzer. This can be purchased from AMI as an option. Compression fittings can only take a few openings and closings before they cease to seal well enough for a trace oxygen analyzer. Flow the gas through the tubing while you attach it to the span fitting: screw it on by one thread allowing the gas to escape around it, and after about 20 seconds tighten it up. This displaces the air from the fitting, meaning that you don't inject a slug of air onto the sensor and delay it coming to stability.

- d) **Tighten fitting on the span gas inlet.**

Use Snoop™ or equivalent to leak check it.

- e) **Press the ALARM HOLD OFF button, and adjust the time displayed to a suitable value (typically 10 minutes).**

Do this so you won't fire the alarms possibly causing all kinds of unnecessary havoc in your control system. Note that doing this will also hold the analog output at its last value.

- f) **Turn the analyzer Sample/Span/Off valve to the SPAN position.**

You will probably see the reading shoot up for a moment as the air in the span gas port is pushed past the sensor, then the reading will start to stabilize.

- g) **Allow to stabilize for 2 minutes.**

This will allow any residual air to be flushed out and the sensor to come to equilibrium.

- h) **Verify that the analyzer reads within about 15% of the span gas value.**

If it doesn't, something is wrong. If the sensor reads very low, check it on air, and if that reading is also very low, replace the sensor (you shouldn't have to do this with a new sensor!) If the reading is too high, it is possible that your span gas is contaminated, or you have a leak, or you have made some kind of error. One thing to note is that if the analyzer temperature is very different from the sensor temperature when you put a new sensor in, the reading will be quite wrong until the sensor has had a chance to equilibrate.

**i) If so, adjust the analyzer span until it reads the span gas value.**

Press the SPAN button. The SPAN flag should appear on the LCD. Press the UP or DOWN arrow buttons until the reading is correct. After a few seconds the SPAN flag will go out and the analyzer will accept the new calibration.

**j) Let it go back to normal operation (the "SPAN" flag goes out on the LCD display), then press the UP arrow and note the number displayed (the "Calibration factor").**

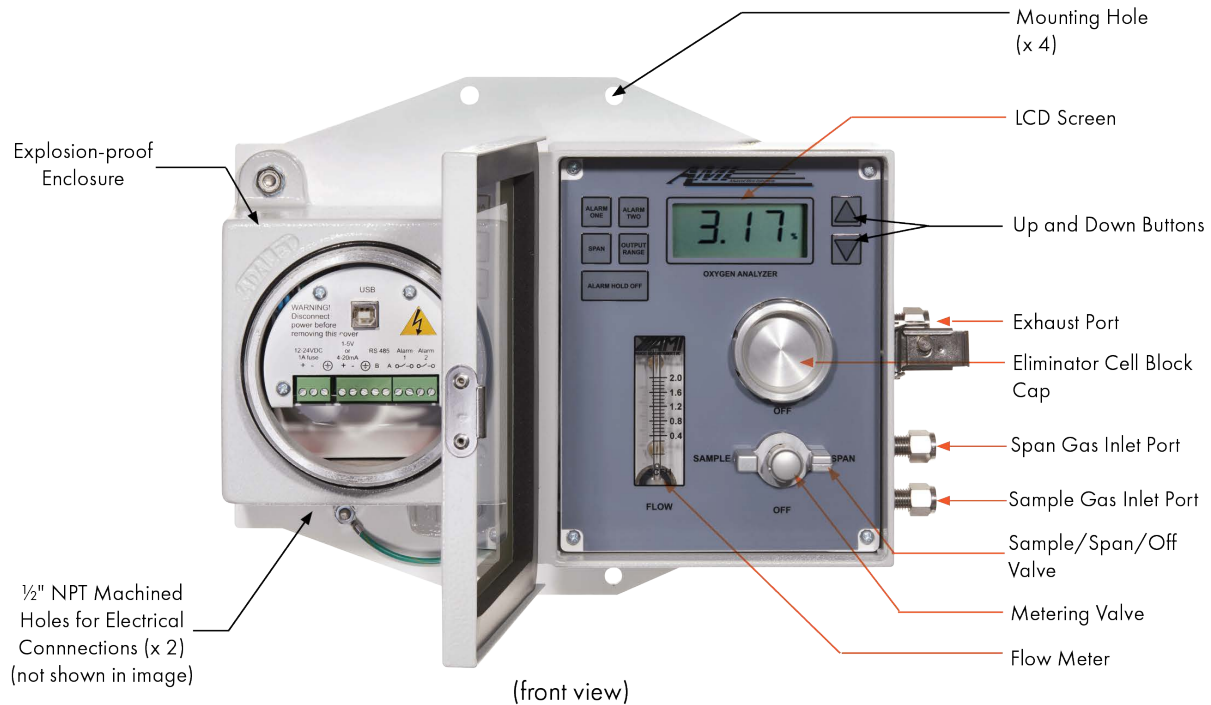
You can use this to get an idea of the remaining cell life in the future. The analyzer also stores the calibration values in memory so you can view the history later. When the sensor is new it will have a Calibration factor (also called Span factor) of about 450. As it gets used up, this number will have to increase when you span the analyzer until it gets up to around 950 or so (the Calibration factor doesn't increase by itself, it only does so when you span the analyzer). You will probably see the span factor remain fairly constant, then suddenly change. When it does so it means that you will need a new sensor soon. The sensor behaves rather like a NiCd battery – it is stable until suddenly it starts to fail.

**k) Rotate the valve back to the Sample position.**

The analyzer is now set up and calibrated. It is normally good practice to give it a day or two and recheck the calibration.

# Analyzer Description

## Basic description:



**Figure 6. Analyzer without lid**

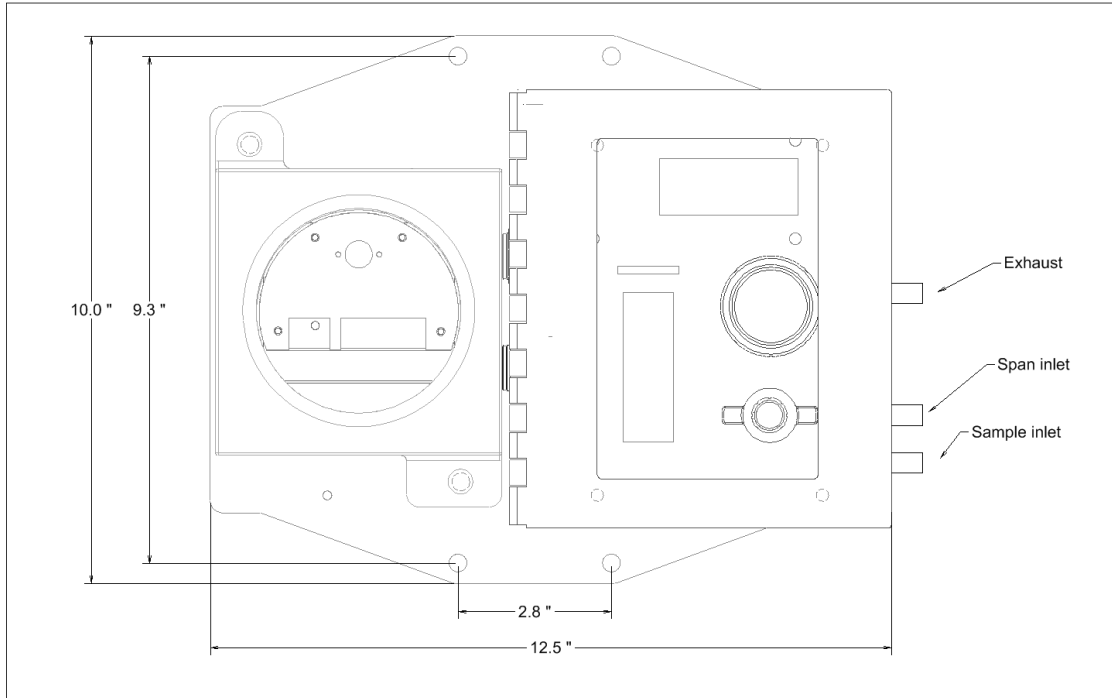
The 210BR measures oxygen in a flammable (or inert) gas stream down to under 0.1%. It is approved for use in hazardous areas when properly installed.

It consists of two major parts mounted on a common back plate. The enclosure on the right contains the gas handling components including the oxygen sensor, and also the controls and analytical circuitry. Optionally, it may also contain a heater for low temperature operation. The circuitry in this right hand enclosure is “intrinsically safe”, meaning that it cannot cause ignition of any flammable gas mixture.

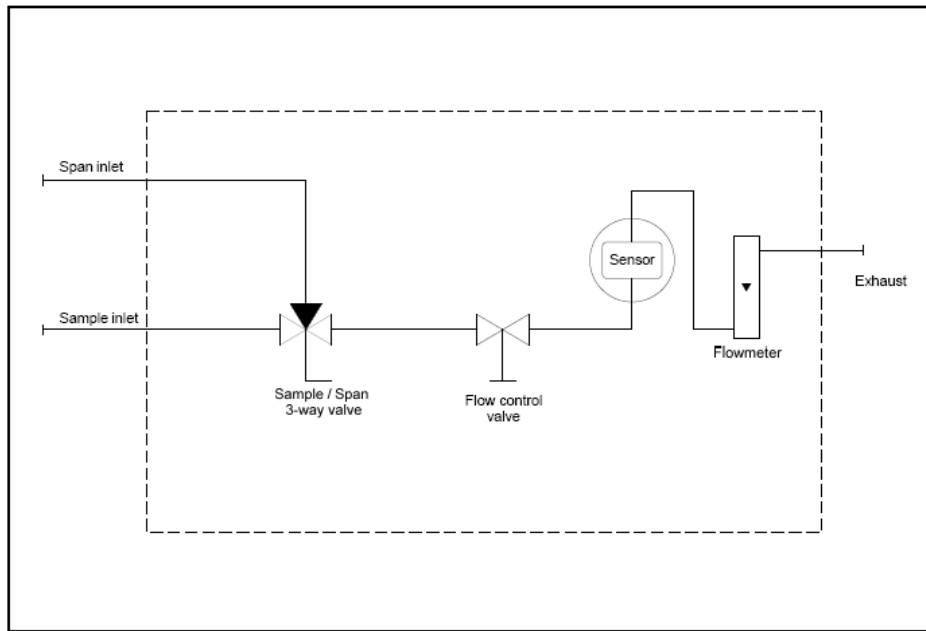
The enclosure on the left is explosion proof. It contains the power supplies, the alarm contacts and output circuitry, the user connections, and the safety barriers for the intrinsically safe section.

The actual oxygen measurement is performed by an oxygen sensor located behind the cell cap on the front of the right enclosure.

# Drawings:

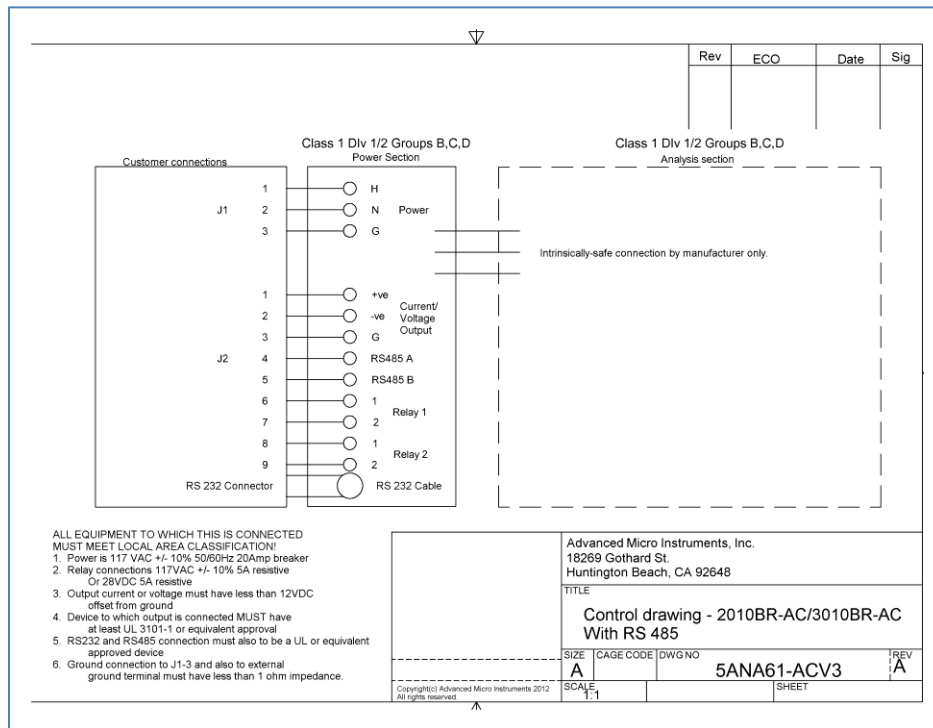


**Figure 7. Outline Drawing**

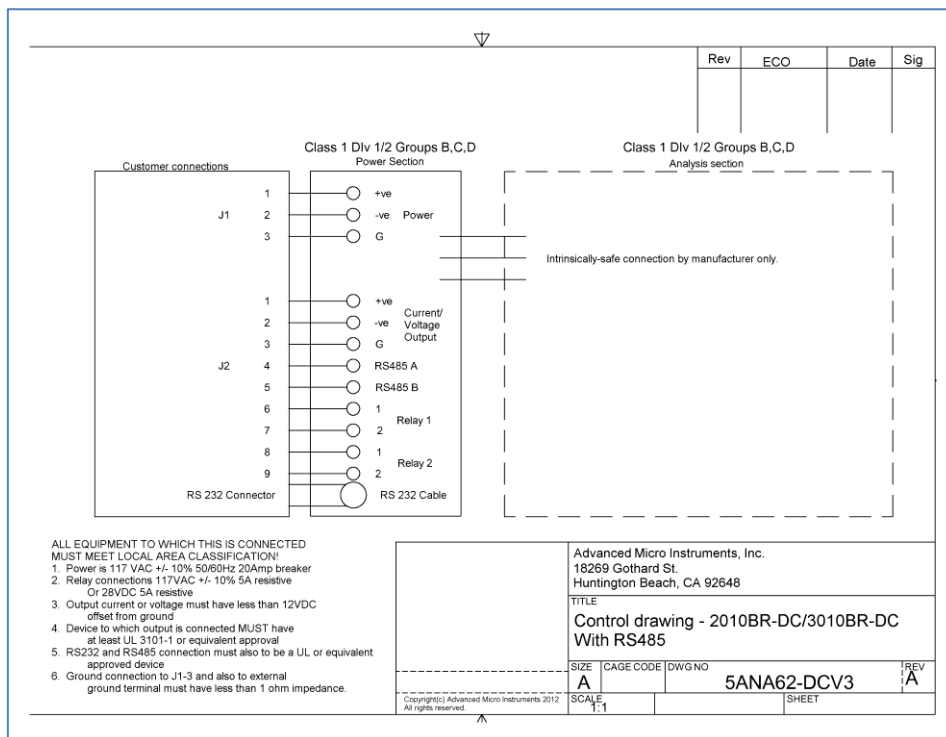


**Figure 8. Flow schematic**





**Figure 9. Control drawing – AC unit**



**Figure 10. Control drawing – DC unit**

# General Information

## Basic knowledge about oxygen measurement

Oxygen is a chemically active gas that is present in the atmosphere at 20.9% concentration. It is essential for animals including humans as it is the active part of air used in breathing. However since it is so active, small amounts of it can cause havoc in situations which are not supposed to have it. In natural gas, for example, small amounts of oxygen cause the other chemicals present in the gas to combine to form acids that destroy piping and chemical systems; in semiconductor manufacturing it changes expensive integrated circuits into sand, or at least stops them from working properly. In chemical operations it can prevent polymerization or otherwise degrade the performance of the process.

Gases obey the gas laws formulated in the end of the 18<sup>th</sup> century and still not well understood by many people. A gas consists of a very large number of independent molecules that fly around in otherwise empty space. Gases don't interact with each other (normally), so that you can treat the behavior of each gas as if no other gases were present. Thus you can consider that air consists of nitrogen at about 11psia, and oxygen at about 3 psia, and various other gases at lower pressures. "psia" stands for Pounds per Square Inch Absolute, i.e. it is the pressure above zero, not the pressure above atmospheric pressure as it would be if we were to use the units psig (Pounds per Square Inch Gauge). Since we are only worried about oxygen, mostly because nitrogen does not matter normally to the chemistry we are worried about, we can think of air as being pure oxygen at 3 psia pressure. In a pure gas stream, or in natural gas, there is zero oxygen ideally, i.e. it is at zero pressure. This means that if there is a leak in the piping, there exists a pressure difference of 3psia forcing oxygen into the leak. The oxygen doesn't care about or see the other gas in the pipe, it thinks of the pipe as being a vacuum. People normally don't intuitively understand this, they think of the gas as being rather like a pipe full of oil in the sea, where if there's a leak oil will come out but it will keep any water out of the pipe. However that's not the way it is with gases because the space between the molecules is very much larger for a gas than it is for a liquid, so one gas does not push another out of the way.

The bottom line is that oxygen from the air will force its way into a pure gas system regardless of the pressure in the system. It will do this through little holes, or through permeable materials such as all plastics or rubbers, to greater or lesser extent. Nitrogen will do this as well, but since nitrogen is comparatively inert normally its presence doesn't matter. Also it is much harder to measure, while oxygen is comparatively easy, hence oxygen is normally used to verify the integrity of the system.

As a consequence of this, the integrity of the oxygen analyzer sample system is critical. AMI analyzers are designed around a patented "Cell block" that integrates all of the sample handling elements into one solid chunk of metal, resulting in much fewer leak sources and therefore much greater reliability, as well as lower cost.

## Analyzer operation

It is just as important that the analyzer's sample system – the components used to control the gas flow – are perfect as the measurement methodology itself. No matter how good the analyzer is, if you don't connect the plumbing correctly you won't get good results.

### Sample tubing and components

For percent level readings, high quality plastic tubing is acceptable but in industrial environments stainless steel is generally preferable. Do not use silicone tubing – the very soft milky material. It is extremely diffusive and will give incorrect readings. Use high quality compression fittings such as “Swagelock™” or “Gyrolock™” and high quality stainless steel filters, valves or regulators if necessary. Make sure that they are assembled correctly and perform a thorough leak test on the sample system before use.

The analyzer expects to see sample pressures between about 1 psig and 150psig. Higher pressures will overwhelm the input valve and make it hard to control the flow. If your pressure is higher than this use a regulator with a stainless steel diaphragm to bring the pressure down appropriately. The analyzer is not very much affected by changes in flow rate and the internal flow meter is adequate for setting the flow.

The span gas pressure should also be held below 100psig. AMI recommends that you use a length of their flexible tubing with O ring seals on its fittings so that you don't damage the analyzer fittings by making and breaking them too often.

### Exhaust

The exhaust port of the analyzer should be given at least a foot of tubing, but it should not be allowed to become pressurized, or the readings will be affected. It should be vented outdoors or brought into a scavenging system. If the latter, have the scavenging system suck in room air around the exhaust line so that the pressure at the exhaust is atmospheric. A typical way of doing this is to have the scavenging system suck on a 1" pipe, and have the ¼" exhaust line from the analyzer extend six inches or so into the end of the pipe.

### Calibrating the analyzer

The oxygen sensor gradually gets used up over its life, and as it does so its sensitivity slowly drops until it is at the end of its life, when the sensitivity drops much faster. Therefore you have to calibrate the sensor every so often to make sure that your readings are correct.

There are two ways of doing this. You can use a span gas, a mixed gas containing a certain level of oxygen in a background gas that ideally matches your sample, but in practice is normally nitrogen, or you can use air. The advantage of using air is that its value really is 20.9% and it doesn't change (except minimally due to humidity changes).

The advantage of using a span gas is that you can calibrate it to a value close to the range of interest. You may have political reasons for having to do this. The disadvantage is that span gases sometimes are incorrectly made, and they can be contaminated by improper handling.

### ***Calibrating with a span gas***

First put a suitable regulator on the span gas tank. Connect the regulator to the analyzer with a flexible line such as that provided by AMI, and leak check the connection with “Snoop™” or similar leak detection fluid. Purge the line for several minutes with a small flow of gas prior to doing this, and leave the gas flowing while you make the connection to the analyzer. This prevents a slug of air from giving you excessively high readings when you start spanning the analyzer.

Make sure the analyzer is seeing a low oxygen level gas – you want the analyzer to go UP to the span gas, not down to it, particularly not from air. Otherwise it can take a long time to get a good calibration.

When all is assembled, turn the flow selector valve on the front of the analyzer to the SPAN position. Span gas is now flowing into the analyzer, and you should see the reading move to the span gas value. Assuming it stabilizes somewhere reasonably close, press the UP or DOWN button until the reading on the LCD shows what the span gas bottle says the value should be. Let go of the buttons, and after a second or two the analyzer will store its calibration value. Return the flow selector valve to the SAMPLE position.

### ***Calibrating with air***

You can either connect a compressed air line – from the plant air, not a bottle of compressed air – to the span port or you can leave the span port open. If you use compressed air, go through the same procedure as above, only adjust the oxygen reading to 20.9%.

If you do not have compressed air, turn the flow selector valve to OFF, and unscrew the cell cap on the front of the analyzer. Blow some air under the sensor by waving a hat or some such at it. Adjust the reading as before to 20.9% and then turn the flow selector valve back to SAMPLE. Then screw the cell cap back on the analyzer.

### ***Alarm Bypass***

Press the alarm bypass button prior to calibration if you have the alarms attached to anything, so as to stop them from going off when the analyzer sees the high oxygen level in the calibration gas. You can adjust the hold off time when you press that button – it shows what the hold off time is, and you can change it with the UP or DOWN buttons as desired. The analog output will also be held constant during this time.

### ***Span problems***

Sometimes you will run into problems. If the sensor is old, it may not be able to come up to the span gas level. If so, you need a new sensor. Sometimes the sensor will calibrate on span gas but will fail on air. This also indicates an old sensor. You can see the sensor state by pressing the UP button when the sensor is showing the oxygen level – it displays the “Span factor”, a number between about 450 and 1000. As the sensor gets old each calibration will increase this number and when it gets up to about 850 it is time to replace the sensor.

Sometimes the sensor won't calibrate on span gas properly, but since it is a new sensor you figure something must be wrong. If something like this is happening, perform an air calibration and allow the

sensor to come back down to a low reading on the sample. Then perform a span gas calibration only don't adjust the span factor, and see what the analyzer says the gas contains. If the gas value isn't what you think it should be, it is the gas that is wrong, not the analyzer, because that air calibration is in fact very valid. You will have to trouble shoot whatever has happened with your gas.

## Using the analyzer

### Output Range

The analyzer displays the oxygen level in appropriate units on the LCD, automatically adjusting its sensitivity as required. Meanwhile the analog output and the alarms (as well as the data log) are set on a single (user selectable) "Output" range.

For example, you can set the analog output to correspond to 0-10%, and the alarms to be 4.0% and 5.0% (i.e. 40% and 50% of range), activating above set point. If the oxygen level actually is 2.5%, the display will show 2.50%, and the output signal will be at 25% of full scale. If the oxygen level becomes 20.0%, the display will show 20.0%, but the 4-20mA output will be saturated, and the alarms will both be activated.

If you now manually change the output range to 0-25%, the reading will stay at 20.0%, the 4-20mA output will go to 80% of scale, and the alarms will de-activate, since they now correspond to 10.0% and 12.5%, i.e. still 40% and 50% of range. However if the alarms were set to latch, you would have to acknowledge them by pressing the ALARM BYPASS button before they would de-activate.

Output ranges	0-1%, 0-5%, 0-10%, 0-25%.
---------------	---------------------------

### Security:

Through the user interface, three levels of security can be set. These are: No security (all front panel controls are active), Span (only the span control and the ALARM BYPASS button are allowed to operate), and Full security (only the ALARM BYPASS button performs a function; other buttons will show settings but won't allow them to be changed). If the front panel controls don't seem to work, use the AMI User Interface to change the security settings.

### Communications

The 210BR supports both a USB link to a local PC, and RS485 over a network. Only one of these can be active at a time, and the unit automatically turns off the RS485 if it detects a computer plugged into the USB connection. Therefore the PC connection over the USB has priority.

The USB connection supports the proprietary AMI protocol, and AMI provides a program on a CD that interfaces with the analyzer. Alternatively it is possible for someone familiar with communications on a PC to directly use the protocol. See the AMI communications manual for details.

The RS485 port supports ModBus RTU at 9600 baud.

These are described in the various communications manuals available on the web site.

## **Advanced Features**

The analyzer has many advanced features that are only accessible through the AMI User Interface. For details see the User Interface manual. The features include a data log, a calibration log, power failure log, and many other detailed bits of data. Most of these features are also available over the ModBus link.

# Maintenance and troubleshooting

## Maintenance:

The model 210BR is virtually maintenance free other than for periodic calibration and occasional sensor replacement.

### Periodic Calibration:

The analyzer should be calibrated about once every month to obtain the best accuracy. The sensor typically declines in sensitivity by about 1% per month, so a monthly calibration is usually satisfactory. Use in a particularly aggressive environment may degrade the sensor faster: in this case calibrate more often.

You can see the calibration history using the user interface as described in the previous section of this manual.

### Sensor Replacement:

This should be done based on the Span Factor feature, rather than as a response to a dead sensor. See the chart below for recommended sensor replacement.

Sensor	Part number	Description	Warrantied life
P-2	4SEN03	Percent oxygen 0-25% - inert gas	9 months
P-3	4SEN04	Percent oxygen – 0-25% CO2 background	6 months
P-4	4SEN08	Percent oxygen – 0-100% - inert gas	6 months
P-5	4SEN19	Percent oxygen – 0-25% CO2 with 500ppm H2S	6 months

**Table 1. AMI percent sensor types**

## Sensor replacement cautions:



---

CAUTION: The sensor contains a caustic or acid liquid. If there is any sign of a liquid in the cell compartment, do not allow it to come into contact with your skin. If it does, immediately flush the affected area with water for a period of at least 15 minutes. Refer to the Material Safety Data Sheet provided

---

**Dispose of leaking or used sensors in accordance with local regulations. Sensors usually contain lead which is toxic, and should generally not be thrown into ordinary trash. Refer to the MSDS to learn about potential hazards and corrective actions in case of any accident.**



*Figure 11. Inserting sensor in cell block*

## Sensor replacement procedure:

1. Turn off the sample gas flow using the flow selection valve on the front panel.
2. Unscrew the cell cap.
3. Remove the old sensor.
4. Open the bag containing the new sensor.
5. Push the new sensor into the block using its handle as shown above.
6. Holding the sensor in place, pull out the stainless steel tag.
7. Allow the reading to stabilize for 45 seconds, then span the reading to 20.9%
8. Turn the valve back to sample.
9. Replace the cell cap.
10. Screw it down tightly but only hand-tight.
11. Dispose of the old sensor in an environmentally appropriate way. It is similar to a lead-acid battery in terms of environmental hazard.



# Troubleshooting

## Basics of oxygen troubleshooting

Most problems are due to either leaks, or a used-up sensor.

Oxygen is of course present in air at about 3psi partial pressure, and the rate at which it diffuses into a gas line is only dependent on the difference in the partial pressure between the gas in the line, and in air. Since there is normally (hopefully) no oxygen in the pipe, that full partial pressure differential drives oxygen into any leak, no matter what the partial pressure of any other gas may be. Any leak therefore will increase the oxygen in the sample. This is also true for span gas – a leak at the regulator on a span gas tank can allow oxygen to flow into the tank, changing its oxygen level and making any spans performed with that gas incorrect.

Typical life expectancy of a sensor is somewhere between six months and two years, depending on oxygen levels. If they are exposed to too much oxygen, they will get used up. Always keep the sensor shorted when it is not in the analyzer. Leave its shorting clip in until you have put it into the cell block, and only then pull the shorting tab out of the sensor.

If the sensor is deeply frozen (below about 25°F), or overheated (above 115°F) the membrane can be damaged and if so, it will no longer read correctly. This may or may not happen. Also, the sensor can be poisoned by excessive levels of H<sub>2</sub>S or other poisonous gases. Any of these things will cause the sensor to read too low.

Reading too high is normally caused by too much oxygen. If you suspect a leak, due to excessive oxygen readings, you can often get an idea of where it is by changing the sample flow rate. If the oxygen reading decreases as you increase the flow rate, that is a sure sign of a leak since the intake of oxygen is pretty constant, but the dilution of that oxygen by the sample is of course greater with a higher flow rate. If you time how long it takes for the reading to decrease, the distance to the leak source is more or less proportional to the time it takes to fall. If it goes down immediately, the source is very close to the sensor – possibly the cell cap is loose, or perhaps an O ring in the analyzer valve is damaged. If it takes a while for the reading to change, the source is further away. It can be very difficult to pin point the source of the leak, but don't give up – the analyzer is essentially a leak detector and it is only doing its job.

Another common problem is a reading that is too low. This is normally due either to a dead sensor, or to an incorrect calibration. If the span gas is contaminated with oxygen, when you span the analyzer you will turn the span down too much to make the reading come out to what you thought it should be. It can be hard to figure this one out: what we suggest when things seem to be confusing is that you perform an air calibration, and then let the sensor stabilize on the sample gas (or nitrogen); then flow the span gas and see what the analyzer reads. The sensor and analyzer are in fact very linear, so if the analyzer now says that the span gas has a lot more oxygen than the label on the tank states, you can be sure that the tank has been contaminated. If so, you have to replace it, and figure out what the reason for the contamination is. Leak-check all the possible leak sources. And remember that it is always possible for the gas supplier to make a mistake. Incidentally, the air calibration is quite accurate, and you can leave it like that with confidence.

A sure sign of a problem is an unexpected span factor. Check the span factor by pressing the UP button immediately after performing a calibration. If this number is below about 350 it indicates that you have spanned the sensor too low – either you have more oxygen than you think in your span gas, or the sensor hasn't equilibrated to a change in temperature yet. If the number is much greater than the last time the analyzer was calibrated, either the sensor has reached the end of its life or there is some other calibration error. Using the user interface, you can read the previous span factors as well. This number always goes up as the sensor ages (it is changed every time you span the analyzer, it doesn't change by itself). So if it goes down, something is wrong. You have more oxygen in the span gas than you thought, (or there is something wrong with the analyzer, but this doesn't happen often).

### ***Analyzer does not power up.***

1. Check that the power is connected correctly, and that you have the appropriate version for your power supply.
2. Check that the power supply voltage is between 10V and 28VDC, or else it is 117VAC (plus or minus 10V).
3. Verify that the power plug is seated in its socket all the way, and that no whiskers of wires are shorting to each other or to the cover.
4. If the user interface can talk to the analyzer, but nothing shows on the LCD, the analytical board or the connection to it has failed.
5. If the LCD shows a number, and once a minute shows "Err", the power board has failed or the internal communication has failed.

### ***Analyzer reads too low***

1. Sensor may not be calibrated. Flow span gas through it and span the analyzer until the analyzer reads appropriately.
2. If the span factor is now too high (up about 999 or so), or if you cannot adjust the span enough to accomplish this, replace the sensor.
3. If the new sensor still reads too low, check its calibration with air and read the span gas - the span gas may be incorrect.
4. If the sensor seems to die quickly, it may be getting poisoned by acid or sulfur bearing gases such as H<sub>2</sub>S. If so, use a higher H<sub>2</sub>S rated sensor such as a P-5.
5. Verify that the cell block connectors are in fact making contact with the cell. Clean them gently with a Q tip, and bend them slightly down so that they make a good contact. Once this is done the cell should have some resistance to being removed from the block.
6. Water may have shorted out the contacts on the back of the sensor. If so, use a Liquid Rejection Probe with an AMI demister or coalescing filter to make sure that condensation does not occur within the analyzer.

7. Verify that the sensor has not been frozen, or cooked. Also verify that the exhaust is not pulling a vacuum on the sensor.

### ***Analyzer reads too high***

1. Verify that there is no flow restriction in the vent line of the analyzer. Check it for mud-dauber wasps.
2. Increase the flow rate through analyzer by adjusting the metering valve - if the reading goes down it indicates a leak in the incoming sample line or the cell block. Use "Snoop™" or equivalent to check all the fittings back to the gas source. If the reading changes immediately, the leak is close by – if it only changes after a while, it is further away. Check such things as welded fittings on pipelines.
3. Leak test all external fittings with "Snoop™" or equivalent.
4. Verify that the gas flow rate is correct. (0.1 to 2 SCFH)
5. Oxygen diffusion can be a serious problem. Verify that no plastic tubing or other plastic components are used in the system, including diaphragms of pressure regulators, packing of valves etc. Verify the analyzer calibration using air as the span gas.
6. Remove the cell (and short it with the metal shorting tag) and verify that the analyzer reads 0.00ppm - if not, there is moisture or corrosion between the sensor contacts in the cell block; clean the contacts and the area around them with isopropyl alcohol, dry with dry compressed air or nitrogen, then replace the cap on the cell block again. Pressurize the system to line pressure (less than 150 psig) and leak check all the fittings and tubing including the sensor block penetrations such as the sensor wire seals (nylon plugs and epoxy seals on the top of the cell block).

---

NOTE: Be careful not to get soap solution on the PC boards!

---

### ***Analyzer reads zero***

1. Verify that the sensor is in the correct position, not upside down. If it is upside down, verify that the membrane has not been punctured - i.e. there is no sign of electrolyte on the surface, and if not, put it back the right way up. If you have left it this way for a while, it may take several hours to recover to a low reading.
2. Verify that the cell block contacts are touching the sensor. Pull the sensor tab, and the contact should hold the sensor with a gentle force. If not, the contacts may be bent. If they have been bent too much, remove the sensor and gently bend them downwards so that they can again make contact.
3. Make sure that the gold plated contact wires are clean. If not, gently clean them with a Q tip or an eraser. Do not use an abrasive cleaner, as it will remove the gold plating.
4. Check the output of the sensor with a DVM configured to measure current. Connect its leads to the two gold rings on the back of the sensor - the center is ground. The output should be around 300 to 550 micro Amps in air (at 70°F). This will take a few minutes to stabilize as the sensor consumes oxygen dissolved in its electrolyte. Replace the sensor if it does not read this amount. See sensor replacement instructions under Maintenance.

### ***No voltage or current output to recording device***

1. Verify that the output wires are properly stripped and connected at the terminal strip.
2. Verify the connections on the output terminal block.
3. Verify that the output connections are not shorted all the way back to the recording device. Disconnect the wires from the analyzer and use an ohmmeter to check for shorts or opens.
4. Use a voltmeter to directly measure the output of the analyzer. If the output is set to voltage, make sure the voltmeter is in voltage mode, and measure between the + and – terminals (not + to GND). If the output is set to current, measure this voltage, but it should be about 15V no matter what the output signal is. Change the voltmeter to its current measurement setting, and measure the current between the + and – terminals. If this is zero, make sure that the voltmeter's internal fuse hasn't blown by measuring a known working current signal with it. Note that you have to disconnect everything else to measure the current properly – you can't simply hook it up along with the load.
5. Verify that the unit is set to the correct output. Remove the output board cover and verify that the switch is in the correct position. This is marked on the PC board itself.

### ***No output alarm indication***

1. Verify the alarm set points are correct - press the appropriate switch on the front panel, and check the displayed reading on the LCD for correct setting.
2. Make sure you understand that the relays act purely as switches – they either connect the two terminals or they disconnect them.
3. Make absolutely sure you haven't connected the power hot to one terminal and the ground to the other. If you have, you probably welded the relay shut or blew the traces off the circuit board or both. You will need to replace the output relay board if so. No we don't cover that under the warranty!
4. Verify that the connections on the terminal block are properly stripped and correct.
5. Verify that the alarms are configured correctly, using a PC or similar communication device.
6. Verify the alarm delay time with the PC.
7. Verify that the output connections are not shorted all the way back to the recording device. Disconnect the wires from the analyzer and use an ohmmeter to check for shorts or opens.

### ***Incorrect readings***

1. Verify that there are no leaks in the system.
2. Verify that the span gas bottle is correctly marked by comparing its reading when the analyzer has been spanned on air to what it actually says.
3. If spanning on air, verify that the air source is free of water vapor (humid air will contain about 3% less oxygen than expected, depending on temperature), and if relevant that air from a tank does actually contain 20.9% oxygen. Manufactured air often does not!



### ***Analyzer refuses to accept front panel settings***




1. Using the USB interface, verify that the security is set the way you want it.



### ***“Err” flashes on the LCD every minute***

1. The internal communication has stopped working. Normally this means that the power section processor has died. Return the unit for service.

## **Accessories**

 <p>Pump module</p>	<p>Draws a sample from a below-atmospheric pressure sample source</p> <p>Handles wide pressure ranges from 14"Hg. to 10psig.</p> <p>Designed for Class 1, Div. 2, Group C,D Area Classifications.</p> <p>Long life pump and motor, 20,000 + hrs. continuous.</p> <p>Unique pump diaphragm that is virtually non diffusive for low level trace applications.</p> <p>Power requirements: 12VDC @ 700mA.</p>
 <p>Extreme weather enclosure</p>	<p>NEMA 4X Enclosure allows for our heated Model 210BR, 210BR and 3010BR to be quickly and easily mounted in place for use in extreme cold, wet and windy weather conditions down to -40° F.</p> <p>Enclosure is predrilled, insulated, powder coat painted and supplied with all hardware for quick and simple installation.</p> <p>Hardware includes: Explosion proof couplings, explosion proof seal-offs, 316S.S. tubing and gas fittings.</p> <p>Dimensions: 21.5"W x 16.5"H x 6.5"D</p>

 <p>"Guardian" Liquid Rejection Probe</p>	<p>Unique membrane and diaphragm design prevent the occasional slugs of liquid gunk traveling down the gas pipeline from flooding out expensive analytical equipment. Prevents costly repair and down time.</p> <p>Break through check valve allows gas to flow in one direction only. This prevents "Air" from being drawn into a flammable gas pipeline via the exhaust port in the event the gas field suddenly experiences a vacuum condition.</p> <p>Available with or without pressure reducing regulator</p> <p>The Guardian automatically drains liquids back into the pipeline without the need for a bypass gas port, which wastes considerable amounts of flammable gas.</p>
 <p>Demister</p>	<p>Very efficiently cools hot saturated sample gas to ambient temperature, causing liquids to coalesce into droplets and return via gravity back to the gas pipeline. The Demister prevents liquids from accumulating down stream in expensive analytical instruments causing costly repairs and down time.</p>
 <p>Calibration tubing</p>	<p>This unique high pressure, non-diffusive sample gas tubing is outfitted with special connection fittings. Designed with an o-ring/swage seal and requiring only finger tightening, the tubing and fittings are rated up to 6,500psig. It continues to provide a leak tight seal even after thousands of connections without causing damage to the female portion of the compression fittings, generally attached to the expensive gas analyzers.</p> <p>With conventional fittings, damage often occurs after just one reconnection simply due to the metal-to-metal swaging design, resulting in gas leaks. Even very minute leaks can wreak havoc with low level ppm oxygen measurements.</p> <p>In addition, the plastic tubing is filled with a Kevlar fiber making it virtually non-diffusive and well suited for high pressure applications. This makes for a perfect choice</p>

	<p>when performing routine calibrations for most gas analyzers, especially trace oxygen.</p> <p>Other plastic tubing such as: Teflon, Tygon, Nylon or Polyethylene diffuse oxygen generally in the range of 2ppm to 100ppm of oxygen per 15' lengths. The amount of diffusion depends on temperature, flow and pressure. Previously, low level trace oxygen measurement required stainless steel or other metallic tubing which is much too cumbersome and prone to failure for routine calibrations.</p> <p>Available for all 1/4" swage type compression fittings. 6,500psig. Rating.</p>
 <p>Calibration gas regulator</p>	<p>This gas nipple with o-ring seal eliminates common leaks associated with imperfect metal to metal surfaces that are common when mating high pressure gas cylinders to pressure reducing regulators.</p> <p>This inexpensive brass nipple and o-ring combination provides a simple and reliable solution to the common occurrence of leaks produced by metal to metal connections.</p> <p>This nipple will fit any pressure reducing regulator inlet with a 1/4" NPT inlet port.</p>
 <p>CD and USB cable</p>	<p>AMI User Interface Program.</p> <p>Allows complete access to all advanced features of the 210BR analyzer.</p>

Contact AMI for information about any of these.

# Specifications and Disclaimer

## Specifications:

210BR Standard ranges:

0 – 1%, 0 – 5%, 0 – 10%, 0 – 25%

Sensitivity: 0.5% of full scale

Repeatability: +/- 1% of full scale at constant temperature

Operating temperature: -4°C to 46°C (25°F - 115°F); -29°C to 46°C (-20°F - 115°F) with optional heater

Humidity: < 85%, non-condensing

Operational conditions: Pollution degree 2, Installation category II.

Drift: +/- 1% of full scale in 4 weeks at constant temperature (dependent on sensor).

Expected cell life: 6 months to 2 years (dependent on sensor).

Response times (upscale):

90% of full scale in less than 30 sec (dependent on sensor).

Outputs: 1-5V or 4-20mA isolated.

Alarm contacts: 117VAC @ 5A, or 28VDC @ 5A, resistive.

Power requirements: 12-24VDC, <80mA, or 117VAC <1W; power increases to ~25W with optional heater.

Absolute Maximum Power voltage 28V DC or 128VAC 60Hz.

Overall dimensions: 15" w x 10" h x 6¼" d.

Mounting hole dimensions: 2.8" w x 9.3" h.

Weight 15 lbs.

**117VAC version is to be installed only in installation (overvoltage) category I or II.**



## **Disclaimer**

Although every effort has been made to assure that the AMI analyzers meet all their performance specifications, AMI takes no responsibility for any losses incurred by reason of the failure of its analyzers or associated components. AMI's obligation is expressly limited to the analyzer itself.

The AMI analyzer is not designed as a primary safety device, that is to say it is not to be used as the primary means of assuring personnel safety. In particular it is not designed to act as a medical instrument, monitoring breathing air for correct oxygen concentration, and should not be used as such when it is the only safety device on the gas system.



# Certificate of Compliance

**Certificate:** 1905645

**Master Contract:** 227773

**Project:** 80023753

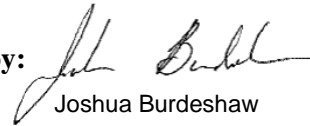
**Date Issued:** 2019-11-05

**Issued To:** Advanced Micro Instruments, Inc.  
225 Paularino Ave  
Costa Mesa, California, 92626  
United States

**Attention:** Charles Schacht

*The products listed below are eligible to bear the CSA Mark shown with adjacent indicators 'C' and 'US' for Canada and US or with adjacent indicator 'US' for US only or without either indicator for Canada only.*

**Issued by:**

  
Joshua Burdeshaw



## **PRODUCTS**

CLASS - C482802 - SIGNAL APPLIANCES Toxic Gas Detection Instruments - For Hazardous Locations

CLASS - C482882 - SIGNAL APPLIANCES-Toxic Gas Detection Instruments For Hazardous Locations.

Certified to U.S. Standards

### **Class I, Division 1, Groups B, C and D:**

Series 2010BR and 210BR Oxygen Analyzers and series 3010BR Hydrogen Sulfide Analyzers, input rated 117Vac, 0.5A max, 50/60Hz or 12-24VDC, 1.7A max or 12-24VDC, 0.1A max; with output rated 1-5V or 4-20mA; with or without built-in heater; provides intrinsically safe output to attached external measurement section (also located in Class I, Div 1, Groups B, C and D); Alarm relay contacts rated 117VAC/5A, 28VDC/5A and Resistive; Temperature Code T3A.



**Certificate:** 1905645  
**Project:** 80023753

**Master Contract:** 227773  
**Date Issued:**

### APPLICABLE REQUIREMENTS

CSA C22.2 No 0-10	General Requirements – Canadian Electrical Code, Part II – Tenth Edition
CSA C22.2 No 30-M1986 (R 2007)	Explosion-Proof Enclosures for Use in Class I Hazardous Locations Industrial Products – Third Edition
CSA C22.2 No 142-M1987 (R 2009)	Process Control Equipment Industrial Products – Third Edition
CSA C22.2 No 157-92 (R 2006)	Intrinsically Safe and Non-Incendive Equipment for Use in Hazardous Locations – Third Edition
UL 913	Intrinsically Safe Apparatus and Associated Apparatus for Use in Class I, II, and III, Division 1, Hazardous (Classified) Locations - Seventh Edition
UL 916	Energy Management Equipment – Fourth Edition
UL 1203	Explosion-Proof and Dust-Ignition-Proof Electrical Equipment for Use in Hazardous (Classified) Locations – Fourth Edition

### MARKINGS

The manufacturer is required to apply the following markings:

- Products shall be marked with the markings specified by the particular product standard.
- Products certified for Canada shall have all Caution and Warning markings in both English and French.

Additional bilingual markings not covered by the product standard(s) may be required by the Authorities Having Jurisdiction. It is the responsibility of the manufacturer to provide and apply these additional markings, where applicable, in accordance with the requirements of those authorities.

The products listed are eligible to bear the CSA Mark shown with adjacent indicators 'C' and 'US' for Canada and US (indicating that products have been manufactured to the requirements of both Canadian and U.S. Standards) or with adjacent indicator 'US' for US only or without either indicator for Canada only.

The following markings are permanently embossed, die-stamped or etched on a metallic nameplate, have a minimum thickness of 0.5mm, which is secured to flow-meter enclosure by two screws.

- Manufacturer's name: "Advanced Micro Instruments", or CSA Master Contract Number "227773", adjacent to the CSA Mark in lieu of manufacturer's name.
- Model number: As specified in the PRODUCTS section, above.
- Electrical ratings: As specified in the PRODUCTS section, above.
- Relay contacts rating: As specified in the PRODUCTS section, above.
- Manufacturing date in MMY format, or serial number, traceable to month of manufacture.
- The CSA Mark with or without "C" and "US" indicators, as shown on the Certificate of Conformity.
- Hazardous Location designation: As specified in the PRODUCTS section, above (may be abbreviated).
- Temperature code: As specified in the PRODUCTS section, above.
- The following words:



**Certificate:** 1905645  
**Project:** 80023753

**Master Contract:** 227773  
**Date Issued:**

- 
- Caution: “Warning – Explosion Hazard – Keep explosion-proof cover tight while circuits are alive. Substitution of components may impair intrinsic safety”



## Supplement to Certificate of Compliance

Certificate: 1905645

Master Contract: 227773

*The products listed, including the latest revision described below, are eligible to be marked in accordance with the referenced Certificate.*

### Product Certification History

---

Project	Date	Description
80023753	2019-11-05	Update report 1905645 and reissue CofC 1905645 to reflect Submitter's new address.  Advanced Micro Instruments 225 Paularino Av Costa Mesa, CA 92626
000070159520	2017-11-28	Variation to REPORT: 1905645 Review drawing pack supplied with application form and analyse effect changes upon compliance. CSA CAN and US Standards marking: Unchanged
0002591862	2013-01-25	Update to report 1905645 to include revised drawings. This update includes component designator changes in the intrinsic safety section and component and drawing number changes in the Explosion proof enclosure section.
0002550588	2012-09-25	Update to report 1905645 to include revised drawings. This update includes three physical changes and six documentation revisions
0002424143	2011-06-10	Update to report 1905645 to include revised drawings.
0002354641	2011-01-18	Update to report 1905645 to include change to electrical rating, replacing a fuse, add a new model variation, and update drawings.
0002225238	2009-10-23	Update to Report 1905645 to include minor electrical and mechanical construction change
0001905645	2007-09-06	Continuation of project 1783712 - I.S. and Explosion-Proof to C/US Division requirements